

Lead-Based Paint Inspection

**Site: Bayshore Towers Apartments
128 Perry Street, Sandusky, OH 44870**



**Prepared for
Erie Metropolitan Housing Authority
322 Warren Street
Sandusky, OH 44870**

**HazCorp Project No. 2021-243
August 6, 2021**

Table of Contents

I. Lead-Based Paint Inspection Information 2
II. Introduction 3
III. Property Description and History 4
IV. XRF Survey 5
V. Inspection Results 6
VI. Conclusions..... 7

- Appendix A - XRF Performance Characteristic Sheet
- Appendix B - XRF Readings
- Appendix C - Site Maps
- Appendix D - Certifications, Licenses

I. Lead-Based Paint Inspection Information

Property Information:

Name: Bayshore Towers Apartments
Address: 128 Perry Street
Sandusky, OH 44870

Owner Information:

Name: Erie Metropolitan Housing Authority
Address: 322 Warren Street
Sandusky, OH 44870
Contact: Mr. Mike Lamarca
Phone: 419.366.2142
Email: mlamarca@eriemetrohousing.org

Company Information

Name: HazCorp Environmental Services, Inc.
Address: 805 Capital Commons Drive
Toledo, Ohio 43615
Telephone: 419.537.6000
Email: hazcorp@sbcglobal.net

Lead Risk Assessors Information:

Name: Charles Long
Telephone: 419.466.7993
License No.: LA7439
Exp. Date: March 31, 2022

Name: Joshua Fry
Telephone: 419.537.6000
License No.: LA9573
Exp. Date: January 20, 2023

II. Introduction

On July 26 & 27, 2021 HazCorp Environmental Services, Inc. conducted a Lead Based Paint Inspection at the multi-family apartment building located at 128 Perry Street in Sandusky, OH. The purpose of this survey was to assess the condition of the painted surfaces at the facility and to determine which contained lead-based paint.

Disclosure Requirements for Residential Units

Ohio law (section 5301.30 of the Revised Code) requires every person who intends to transfer any residential real property by sale, land installment contract, lease with option to purchase, exchange, or lease for a term of ninety-nine years and renewable forever, to complete and provide a copy to the perspective transferee of the applicable property disclosure forms, disclosing known hazardous conditions of the property, including lead-based paint hazards.

Federal law (24 CFR part 35 and 40 CFR part 745) requires sellers and lessors of residential units constructed prior to 1978, except housing for the elderly or persons with disabilities (unless any child who is less than six years of age resides or is expected to reside in such housing) or any zero-bedroom dwelling to disclose and provide a copy of this report to new purchasers or lessees before they become obligated under a lease or sales contract. Property owners and sellers are also required to distribute an educational pamphlet approved by the United States Environmental Protection Agency and include standard warning language in leases or sales contracts to ensure that parents have the information they need to protect children from lead-based paint hazards.

III. Property Description and History

Bayshore Towers Apartments is a multi-family apartment building owned and operated by Erie Metropolitan Housing Authority. Due to occupancy restrictions tenants below the age of 18 are not allowed to reside in the building.

The inspected facility is a twelve-story high-rise apartment building that was constructed in 1969. The building underwent major renovations in 2006 when the majority of the 134 residential units were completely remodeled. Units on floors 10, 11, and 12 were not remodeled as extensively as the lower floor units.

The exterior of the building is unpainted concrete with modern metal frame windows with a factory coating. The apartments are a mixture of efficiency, one bedroom, and two bedroom units. Each unit consists of a single living room/kitchen and at least one bathroom. In the efficiency units the sleeping area is combined with the living room/kitchen; while in the one and two bedroom units they have as the name implies separate bedrooms. A single bathroom is attached to each bedroom.

The walls throughout each unit are drywall, while the ceilings in the units are a mixture of drywall and unpainted popcorn finish on the concrete decking. The doors and door frames are a mixture of wood and metal. Cabinets in the units were installed during the 2006 renovations. Heat for the units is supplied by baseboard heaters. Most units have in-wall air conditioners to provide cooling. In the common areas (halls and 1st floor common spaces) the walls are mostly drywall and the ceilings are unpainted suspended ceiling panels. The stairwells and the areas surrounding the elevators have concrete block walls.

IV. XRF Survey

During this inspection a Niton Model No. XLp-300A X-Ray Fluorescence (XRF) Detector with serial number 7934 was used. The Niton XLp-300A is a state-of-the-art XRF Detector that does not require substrate correction and does not have an inconclusive range. The Performance Characteristic Sheet (PCS) for this instrument can be found in Appendix A. The source for the instrument used during this assessment is a 40 mCi Cadmium 109 source that was installed in 2021. The instrument was calibrated and operated in K + L Mode. Mr. Charles Long and Mr. Joshua Fry operated the XRF during this survey. In addition to Lead Risk Assessor training, which includes basic XRF use and radiation safety, Mr. Long and Mr. Fry has received instrument training from Niton on how to specifically operate the XLp-300A.

At the start of each inspection an internal shutter calibration was performed in addition to the standard paint-film calibration check. The calibration check was performed by “testing” a known paint-film standard, SRM 2573, three times. The paint-film standard used during the calibration was supplied by Niton, the manufacturer of the instrument. The National Institute of Standards and Technology (NIST) Certificate of Analysis for SRM 2573 can be found in Appendix D. All three tests were within the acceptable tolerance range for that particular paint-film standard. The calibration check passed and the instrument was found to be functioning properly. Additional calibration checks were conducted every four hours and at the end of the survey each day.

Given the extensive knowledge of Erie Metropolitan Housing Authority regarding the building’s history a Targeted Sampling Strategy was employed. Using Table 5.6 of the HUD Guidelines a total of 19 targeted units were selected for testing. The targeted units were selected by Erie Metropolitan Housing Authority. The 19 selected units and all common areas where tenants have access were tested. Restricted access areas such as maintenance shops were not tested.

The inspection consisted of examining all the painted surfaces in a room and then testing all four walls in each room and each unique testing combination. A testing combination is a unique combination of room equivalent, building component type and substrate, a room equivalent is a room and any adjoining areas (i.e. closets) which are likely to have the same paint history. For example, the wood baseboards in a room and its adjoining closet are considered one testing combination.

The suspect locations were tested with the XRF until either a negative or positive result was given. As can be seen in the XRF Reading spreadsheet found in Appendix B some of the results are recorded as NULL. In these isolated cases the instrument was removed from the surface before an accurate reading was attained. If a NULL reading was recorded for a specific testing combination it was re-tested until a confirmed negative or positive result was obtained.

During the survey certain information was recorded for each component tested. This information includes component name, substrate, condition of paint, color of paint, component location (building number, unit number, floor number, room identifier and side of room) and lead content. The side of each room is assigned a letter A, B, C or D. In each room the wall closest to Perry Street was assigned the letter A, with remaining walls assigned B, C, and D in a clockwise manner.

V. Inspection Results

The results of the XRF survey, which are included in Appendix B, show that no surfaces were found to contain lead-based paint. Therefore, no Lead-Paint Hazards were found during this inspection.

VI. Conclusions

Based on this Lead-Based Paint Inspection which was conducted in accordance with HUD Guidelines and Ohio Department of Health regulations, Lead-Based Paint is *not present* or accessible within the residential units or common areas of this building.

Although it doesn't apply to this building due to a lack of lead-base paint it should be noted that EPA requires that firms performing renovation, repair, and painting projects that disturb lead-based paint in pre-1978 homes, child care facilities and schools be certified by EPA and that they use certified renovators who are trained by EPA-approved training providers to follow lead-safe work practices. Contractors must follow lead-safe work practices and follow these simple steps:

- Contain the work area.
- Minimize dust.
- Clean up thoroughly.

It should be noted that the above-referenced EPA rule does not generally apply to minor maintenance or repair activities that disturb less than six square feet in any one room or less than 20 square feet on the exterior.

Signature



Charles Long
HazCorp Environmental Services, Inc.
ODH License No. LA-7439, Exp.: 03/31/22



Joshuah Fry
HazCorp Environmental Services, Inc.
ODH License No. LA-9573 , Exp.:01/20/2023

Appendix A

XRF Performance Characteristic Sheet

Performance Characteristic Sheet

EFFECTIVE DATE: September 24, 2004

EDITION NO.: 1

MANUFACTURER AND MODEL:

Make: Niton LLC

Tested Model: XLp 300

Source: ^{109}Cd

Note: This PCS is also applicable to the equivalent model variations indicated below, for the Lead-in-Paint K+L variable reading time mode, in the XLi and XLp series:

XLi 300A, XLi 301A, XLi 302A and XLi 303A.

XLp 300A, XLp 301A, XLp 302A and XLp 303A.

XLi 700A, XLi 701A, XLi 702A and XLi 703A.

XLp 700A, XLp 701A, XLp 702A and XLp 703A.

Note: The XLi and XLp versions refer to the shape of the handle part of the instrument. The differences in the model numbers reflect other modes available, in addition to Lead-in-Paint modes. The manufacturer states that specifications for these instruments are identical for the source, detector, and detector electronics relative to the Lead-in-Paint mode.

FIELD OPERATION GUIDANCE

OPERATING PARAMETERS:

Lead-in-Paint K+L variable reading time mode.

XRF CALIBRATION CHECK LIMITS:

0.8 to 1.2 mg/cm² (inclusive)

The calibration of the XRF instrument should be checked using the paint film nearest 1.0 mg/cm² in the NIST Standard Reference Material (SRM) used (e.g., for NIST SRM 2579, use the 1.02 mg/cm² film).

If readings are outside the acceptable calibration check range, follow the manufacturer's instructions to bring the instruments into control before XRF testing proceeds.

SUBSTRATE CORRECTION:

For XRF results using Lead-in-Paint K+L variable reading time mode, substrate correction is not needed for:

Brick, Concrete, Drywall, Metal, Plaster, and Wood

INCONCLUSIVE RANGE OR THRESHOLD:

K+L MODE READING DESCRIPTION	SUBSTRATE	THRESHOLD (mg/cm ²)
Results not corrected for substrate bias on any substrate	Brick	1.0
	Concrete	1.0
	Drywall	1.0
	Metal	1.0
	Plaster	1.0
	Wood	1.0

BACKGROUND INFORMATION

EVALUATION DATA SOURCE AND DATE:

This sheet is supplemental information to be used in conjunction with Chapter 7 of the HUD *Guidelines for the Evaluation and Control of Lead-Based Paint Hazards in Housing* ("HUD Guidelines"). Performance parameters shown on this sheet are calculated from the EPA/HUD evaluation using archived building components. Testing was conducted in August 2004 on 133 testing combinations. The instruments that were used to perform the testing had new sources; one instrument's was installed in November 2003 with 40 mCi initial strength, and the other's was installed June 2004 with 40 mCi initial strength.

OPERATING PARAMETERS:

Performance parameters shown in this sheet are applicable only when properly operating the instrument using the manufacturer's instructions and procedures described in Chapter 7 of the HUD Guidelines.

SUBSTRATE CORRECTION VALUE COMPUTATION:

Substrate correction is not needed for brick, concrete, drywall, metal, plaster or wood when using Lead-in-Paint K+L variable reading time mode, the normal operating mode for these instruments. If substrate correction is desired, refer to Chapter 7 of the HUD Guidelines for guidance on correcting XRF results for substrate bias.

EVALUATING THE QUALITY OF XRF TESTING:

Randomly select ten testing combinations for retesting from each house or from two randomly selected units in multifamily housing. Use the K+L variable time mode readings.

Conduct XRF retesting at the ten testing combinations selected for retesting.

Determine if the XRF testing in the units or house passed or failed the test by applying the steps below.

Compute the Retest Tolerance Limit by the following steps:

Determine XRF results for the original and retest XRF readings. Do not correct the original or retest results for substrate bias. In single-family and multifamily housing, a result is defined as a single reading. Therefore, there will be ten original and ten retest XRF results for each house or for the two selected units.

Calculate the average of the original XRF result and retest XRF result for each testing combination.

Square the average for each testing combination.

Add the ten squared averages together. Call this quantity C.

Multiply the number C by 0.0072. Call this quantity D.

Add the number 0.032 to D. Call this quantity E.

Take the square root of E. Call this quantity F.

Multiply F by 1.645. The result is the Retest Tolerance Limit.

Compute the average of all ten original XRF results.

Compute the average of all ten re-test XRF results.

Find the absolute difference of the two averages.

If the difference is less than the Retest Tolerance Limit, the inspection has passed the retest. If

the difference of the overall averages equals or exceeds the Retest Tolerance Limit, this procedure should be repeated with ten new testing combinations. If the difference of the overall averages is equal to or greater than the Retest Tolerance Limit a second time, then the inspection should be considered deficient.

Use of this procedure is estimated to produce a spurious result approximately 1% of the time. That is, results of this procedure will call for further examination when no examination is warranted in approximately 1 out of 100 dwelling units tested.

TESTING TIMES:

For the Lead-in-Paint K+L variable reading time mode, the instrument continues to read until it is moved away from the testing surface, terminated by the user, or the instrument software indicates the reading is complete. The following table provides testing time information for this testing mode. The times have been adjusted for source decay, normalized to the initial source strengths as noted above. Source strength and type of substrate will affect actual testing times. At the time of testing, the instruments had source strengths of 26.6 and 36.6 mCi.

Testing Times Using K+L Reading Mode (Seconds)						
Substrate	All Data			Median for laboratory-measured lead levels (mg/cm ²)		
	25 th Percentile	Median	75 th Percentile	Pb < 0.25	0.25 ≤ Pb < 1.0	1.0 ≤ Pb
Wood Drywall	4	11	19	11	15	11
Metal	4	12	18	9	12	14
Brick Concrete Plaster	8	16	22	15	18	16

CLASSIFICATION RESULTS:

XRF results are classified as positive if they are greater than or equal to the threshold, and negative if they are less than the threshold.

DOCUMENTATION:

A document titled *Methodology for XRF Performance Characteristic Sheets* provides an explanation of the statistical methodology used to construct the data in the sheets, and provides empirical results from using the recommended inconclusive ranges or thresholds for specific XRF instruments. For a copy of this document call the National Lead Information Center Clearinghouse at 1-800-424-LEAD.

This XRF Performance Characteristic Sheet was developed by the Midwest Research Institute (MRI) and QuanTech, Inc., under a contract between MRI and the XRF manufacturer. HUD has determined that the information provided here is acceptable when used as guidance in conjunction with Chapter 7, Lead-Based Paint Inspection, of HUD's *Guidelines for the Evaluation and Control of Lead-Based Paint Hazards in Housing*.

Appendix B
XRF Readings

XRF Readings
 Site: Bayshore Towers Apartments
 128 Perry Street
 Sandusky, OH 44870

Lead Risk Assessors:
 Charles Long / Joshua Fry

Time	Component	Substrate	Side	Condition	Color	Floor	Room	Apt. #	Results	PbC	Units	PbC Error
7/26/2021 9:41	CALCHECK								Positive	1	mg / cm ^2	0.1
7/26/2021 9:42	CALCHECK								Positive	1.1	mg / cm ^2	0.1
7/26/2021 9:42	CALCHECK								Negative	0.9	mg / cm ^2	0.1
7/26/2021 9:52	WALL	DRYWALL	D	INTACT	BEIGE	12	LIVING ROOM	1204	Negative	0	mg / cm ^2	0.02
7/26/2021 9:52	WALL	DRYWALL	A	INTACT	BEIGE	12	LIVING ROOM	1204	Negative	0	mg / cm ^2	0.02
7/26/2021 9:53	WALL	DRYWALL	B	INTACT	BEIGE	12	LIVING ROOM	1204	Negative	0	mg / cm ^2	0.02
7/26/2021 9:53	WALL	DRYWALL	C	INTACT	BEIGE	12	LIVING ROOM	1204	Negative	0	mg / cm ^2	0.02
7/26/2021 9:55	CEILING	DRYWALL		INTACT	BEIGE	12	LIVING ROOM	1204	Negative	0.02	mg / cm ^2	0.03
7/26/2021 9:57	CEILING	DRYWALL		INTACT	BEIGE	12	BEDROOM	1204	Negative	0	mg / cm ^2	0.02
7/26/2021 9:58	WALL	DRYWALL	A	INTACT	BEIGE	12	BATHROOM	1204	Negative	0.4	mg / cm ^2	0.4
7/26/2021 9:58	WALL	DRYWALL	B	INTACT	BEIGE	12	BATHROOM	1204	Negative	0.01	mg / cm ^2	0.02
7/26/2021 9:58	WALL	DRYWALL	C	INTACT	BEIGE	12	BATHROOM	1204	Negative	0.01	mg / cm ^2	0.02
7/26/2021 9:59	WALL	DRYWALL	D	INTACT	BEIGE	12	BATHROOM	1204	Negative	0.6	mg / cm ^2	0.4
7/26/2021 10:00	DOOR FRAME	METAL	A	INTACT	BEIGE	12	BATHROOM	1204	Negative	0.03	mg / cm ^2	0.04
7/26/2021 10:02	HEATER	METAL	A	INTACT	BEIGE	12	LIVING ROOM	1204	Negative	0.02	mg / cm ^2	0.02
7/26/2021 10:03	DOOR FRAME	METAL	C	INTACT	BEIGE	12	LIVING ROOM	1204	Negative	0.01	mg / cm ^2	0.02
7/26/2021 10:05	DOOR FRAME	METAL	A	INTACT	BEIGE	12	LIVING ROOM	1203	Negative	0	mg / cm ^2	0.02
7/26/2021 10:06	WALL	DRYWALL	A	INTACT	BEIGE	12	LIVING ROOM	1203	Negative	0	mg / cm ^2	0.02
7/26/2021 10:06	WALL	DRYWALL	B	INTACT	BEIGE	12	LIVING ROOM	1203	Negative	0	mg / cm ^2	0.02
7/26/2021 10:07	WALL	DRYWALL	C	INTACT	BEIGE	12	LIVING ROOM	1203	Negative	0	mg / cm ^2	0.02
7/26/2021 10:07	WALL	DRYWALL	D	INTACT	BEIGE	12	LIVING ROOM	1203	Negative	0.5	mg / cm ^2	0.3
7/26/2021 10:07	CEILING	DRYWALL		INTACT	BEIGE	12	LIVING ROOM	1203	Negative	0	mg / cm ^2	0.02
7/26/2021 10:08	CEILING	DRYWALL		INTACT	BEIGE	12	BATHROOM	1203	Negative	0	mg / cm ^2	0.02
7/26/2021 10:08	WALL	DRYWALL	D	INTACT	BEIGE	12	BATHROOM	1203	Negative	0	mg / cm ^2	0.02
7/26/2021 10:09	WALL	DRYWALL	A	INTACT	BEIGE	12	BATHROOM	1203	Negative	0	mg / cm ^2	0.02
7/26/2021 10:09	WALL	DRYWALL	B	INTACT	BEIGE	12	BATHROOM	1203	Negative	0	mg / cm ^2	0.02
7/26/2021 10:10	WALL	DRYWALL	C	INTACT	BEIGE	12	BATHROOM	1203	Negative	0	mg / cm ^2	0.02
7/26/2021 10:11	DOOR FRAME	METAL	C	INTACT	BEIGE	12	BATHROOM	1203	Negative	0.01	mg / cm ^2	0.02
7/26/2021 10:12	HEATER	METAL	C	INTACT	BEIGE	12	BATHROOM	1203	Negative	-0.21	mg / cm ^2	0.78
7/26/2021 10:14	ELEV DOOR	METAL	C	INTACT	BROWN	12	HALL	COMMON	Negative	0.05	mg / cm ^2	0.03
7/26/2021 10:15	ELEV DOOR FRAME	METAL	C	INTACT	BROWN	12	HALL	COMMON	Negative	0.04	mg / cm ^2	0.04
7/26/2021 10:16	HEATER	METAL	A	INTACT	BROWN	12	HALL	COMMON	Negative	0	mg / cm ^2	0.02
7/26/2021 10:16	DOOR	METAL	A	INTACT	RED	12	HALL	COMMON	Negative	0.4	mg / cm ^2	0.1
7/26/2021 10:17	DOOR FRAME	METAL	A	INTACT	RED	12	HALL	COMMON	Negative	0.26	mg / cm ^2	0.05
7/26/2021 10:19	WALL	DRYWALL	A	INTACT	BEIGE	12	HALL	COMMON	Negative	0	mg / cm ^2	0.02

XRF Readings
 Site: Bayshore Towers Apartments
 128 Perry Street
 Sandusky, OH 44870

Lead Risk Assessors:
 Charles Long / Joshua Fry

Time	Component	Substrate	Side	Condition	Color	Floor	Room	Apt. #	Results	PbC	Units	PbC Error
7/26/2021 10:19	WALL	DRYWALL	B	INTACT	BEIGE	12	HALL	COMMON	Negative	0	mg / cm ^2	0.02
7/26/2021 10:19	WALL	DRYWALL	C	INTACT	BEIGE	12	HALL	COMMON	Negative	0	mg / cm ^2	0.02
7/26/2021 10:20	WALL	DRYWALL	D	INTACT	BEIGE	12	HALL	COMMON	Negative	0	mg / cm ^2	0.02
7/26/2021 10:21	DOOR	WOOD	A	INTACT	BROWN	12	HALL	COMMON	Negative	0	mg / cm ^2	0.02
7/26/2021 10:22	DOOR PLUMBING	METAL	A	INTACT	BEIGE	12	HALL	COMMON	Negative	0	mg / cm ^2	0.02
7/26/2021 10:28	WALL	DRYWALL	A	INTACT	BEIGE	11	LIVING ROOM	1112	Negative	0	mg / cm ^2	0.02
7/26/2021 10:29	WALL	DRYWALL	B	INTACT	WHITE	11	LIVING ROOM	1112	Negative	0	mg / cm ^2	0.02
7/26/2021 10:29	WALL	DRYWALL	C	INTACT	WHITE	11	LIVING ROOM	1112	Negative	0	mg / cm ^2	0.02
7/26/2021 10:30	WALL	DRYWALL	D	INTACT	WHITE	11	LIVING ROOM	1112	Negative	0	mg / cm ^2	0.02
7/26/2021 10:30	CEILING	DRYWALL		INTACT	WHITE	11	LIVING ROOM	1112	Negative	0.01	mg / cm ^2	0.05
7/26/2021 10:31	HEATER	METAL	A	INTACT	WHITE	11	LIVING ROOM	1112	Negative	0.01	mg / cm ^2	0.04
7/26/2021 10:33	DOOR FRAME	METAL	C	INTACT	WHITE	11	LIVING ROOM	1112	Negative	0	mg / cm ^2	0.02
7/26/2021 10:34	WALL	DRYWALL	A	INTACT	WHITE	11	BATHROOM	1112	Negative	0	mg / cm ^2	0.02
7/26/2021 10:34	WALL	DRYWALL	B	INTACT	WHITE	11	BATHROOM	1112	Negative	0.03	mg / cm ^2	0.07
7/26/2021 10:34	WALL	DRYWALL	C	INTACT	WHITE	11	BATHROOM	1112	Negative	0.01	mg / cm ^2	0.04
7/26/2021 10:36	WALL	DRYWALL	D	INTACT	WHITE	11	BATHROOM	1112	Negative	0.03	mg / cm ^2	0.11
7/26/2021 10:36	CEILING	DRYWALL		INTACT	WHITE	11	BATHROOM	1112	Negative	0	mg / cm ^2	0.02
7/26/2021 10:39	CEILING	DRYWALL		INTACT	WHITE	11	LIVING ROOM	1113	Negative	0.01	mg / cm ^2	0.03
7/26/2021 10:40	WALL	DRYWALL	A	INTACT	WHITE	11	LIVING ROOM	1113	Negative	0.01	mg / cm ^2	0.03
7/26/2021 10:40	WALL	DRYWALL	B	INTACT	WHITE	11	LIVING ROOM	1113	Negative	0	mg / cm ^2	0.02
7/26/2021 10:40	WALL	DRYWALL	C	INTACT	WHITE	11	LIVING ROOM	1113	Negative	0	mg / cm ^2	0.02
7/26/2021 10:41	WALL	DRYWALL	D	INTACT	WHITE	11	LIVING ROOM	1113	Negative	0	mg / cm ^2	0.02
7/26/2021 10:41	HEATER	METAL	C	INTACT	WHITE	11	LIVING ROOM	1113	Null	0	mg / cm ^2	0.02
7/26/2021 10:41	HEATER	METAL	C	INTACT	WHITE	11	LIVING ROOM	1113	Negative	0	mg / cm ^2	0.02
7/26/2021 10:42	DOOR FRAME	METAL	A	INTACT	WHITE	11	LIVING ROOM	1113	Negative	0	mg / cm ^2	0.02
7/26/2021 10:43	DOOR FRAME	METAL	C	INTACT	WHITE	11	BATHROOM	1113	Negative	0.01	mg / cm ^2	0.03
7/26/2021 10:43	WALL	DRYWALL	C	INTACT	WHITE	11	BATHROOM	1113	Negative	0.02	mg / cm ^2	0.04
7/26/2021 10:43	WALL	DRYWALL	D	INTACT	WHITE	11	BATHROOM	1113	Negative	0.01	mg / cm ^2	0.03
7/26/2021 10:44	WALL	DRYWALL	A	INTACT	WHITE	11	BATHROOM	1113	Negative	0	mg / cm ^2	0.02
7/26/2021 10:44	WALL	DRYWALL	B	INTACT	WHITE	11	BATHROOM	1113	Negative	0	mg / cm ^2	0.02
7/26/2021 10:44	CEILING	DRYWALL		INTACT	WHITE	11	BATHROOM	1113	Negative	0	mg / cm ^2	0.02
7/26/2021 10:46	DOOR	WOOD	A	INTACT	BLUE	11	HALL	COMMON	Negative	0	mg / cm ^2	0.02
7/26/2021 10:46	DOOR FRAME	WOOD	A	INTACT	BLUE	11	HALL	COMMON	Negative	0.01	mg / cm ^2	0.02
7/26/2021 10:47	HEATER	METAL	A	INTACT	BLUE	11	HALL	COMMON	Negative	0.05	mg / cm ^2	0.05
7/26/2021 10:50	WALL	CONCRETE	C	INTACT	GREEN	10	HALL	COMMON	Negative	0	mg / cm ^2	0.02

XRF Readings
 Site: Bayshore Towers Apartments
 128 Perry Street
 Sandusky, OH 44870

Lead Risk Assessors:
 Charles Long / Joshua Fry

Time	Component	Substrate	Side	Condition	Color	Floor	Room	Apt. #	Results	PbC	Units	PbC Error
7/26/2021 10:51	ELEV DOOR	METAL	C	INTACT	GREEN	10	HALL	COMMON	Negative	0.04	mg / cm ^2	0.05
7/26/2021 10:51	ELEV DOOR FRAME	METAL	C	INTACT	GREEN	10	HALL	COMMON	Negative	0.03	mg / cm ^2	0.05
7/26/2021 10:55	WALL	DRYWALL	A	INTACT	WHITE	10	LIVING ROOM	1011	Negative	0	mg / cm ^2	0.02
7/26/2021 10:55	WALL	DRYWALL	B	INTACT	WHITE	10	LIVING ROOM	1011	Negative	0	mg / cm ^2	0.02
7/26/2021 10:56	WALL	DRYWALL	C	INTACT	WHITE	10	LIVING ROOM	1011	Negative	0	mg / cm ^2	0.02
7/26/2021 10:56	WALL	DRYWALL	D	INTACT	WHITE	10	LIVING ROOM	1011	Negative	0	mg / cm ^2	0.02
7/26/2021 10:57	CEILING	DRYWALL		INTACT	WHITE	10	LIVING ROOM	1011	Negative	0	mg / cm ^2	0.02
7/26/2021 10:58	HEATER	METAL	C	INTACT	WHITE	10	LIVING ROOM	1011	Negative	0.01	mg / cm ^2	0.03
7/26/2021 10:58	DOOR FRAME	METAL	B	INTACT	WHITE	10	LIVING ROOM	1011	Negative	0	mg / cm ^2	0.02
7/26/2021 10:59	DOOR	WOOD	B	INTACT	WHITE	10	LIVING ROOM	1011	Negative	0	mg / cm ^2	0.02
7/26/2021 10:59	DOOR	WOOD	A	INTACT	WHITE	10	BEDROOM	1011	Negative	0	mg / cm ^2	0.02
7/26/2021 11:00	DOOR FRAME	METAL	A	INTACT	WHITE	10	BEDROOM	1011	Negative	0	mg / cm ^2	0.02
7/26/2021 11:00	WALL	DRYWALL	A	INTACT	WHITE	10	BEDROOM	1011	Negative	0	mg / cm ^2	0.02
7/26/2021 11:01	WALL	DRYWALL	B	INTACT	WHITE	10	BEDROOM	1011	Negative	0	mg / cm ^2	0.02
7/26/2021 11:01	WALL	DRYWALL	C	INTACT	WHITE	10	BEDROOM	1011	Negative	0	mg / cm ^2	0.02
7/26/2021 11:01	WALL	DRYWALL	D	INTACT	WHITE	10	BEDROOM	1011	Negative	0	mg / cm ^2	0.02
7/26/2021 11:02	CEILING		D	INTACT	WHITE	10	BEDROOM	1011	Negative	0	mg / cm ^2	0.02
7/26/2021 11:02	CEILING		D	INTACT	WHITE	10	BATHROOM	1011	Negative	0	mg / cm ^2	0.02
7/26/2021 11:03	WALL	DRYWALL	A	INTACT	WHITE	10	BATHROOM	1011	Negative	0	mg / cm ^2	0.02
7/26/2021 11:03	WALL	DRYWALL	B	INTACT	WHITE	10	BATHROOM	1011	Negative	0	mg / cm ^2	0.02
7/26/2021 11:03	WALL	DRYWALL	C	INTACT	WHITE	10	BATHROOM	1011	Negative	0	mg / cm ^2	0.02
7/26/2021 11:04	WALL	DRYWALL	D	INTACT	WHITE	10	BATHROOM	1011	Negative	0.5	mg / cm ^2	0.4
7/26/2021 11:04	DOOR	WOOD	C	INTACT	WHITE	10	BATHROOM	1011	Negative	0	mg / cm ^2	0.02
7/26/2021 11:05	DOOR FRAME	METAL	C	INTACT	WHITE	10	BATHROOM	1011	Negative	0	mg / cm ^2	0.02
7/26/2021 11:06	DOOR	METAL	D	INTACT	WHITE	10	LIVING ROOM	1011	Negative	0	mg / cm ^2	0.02
7/26/2021 11:06	CEILING	DRYWALL		INTACT	WHITE	10	LIVING ROOM	1011	Negative	0	mg / cm ^2	0.02
7/26/2021 11:08	CEILING	DRYWALL		INTACT	WHITE	10	LIVING ROOM	1006	Negative	0.01	mg / cm ^2	0.02
7/26/2021 11:09	WALL	DRYWALL	A	INTACT	WHITE	10	LIVING ROOM	1006	Negative	0.6	mg / cm ^2	0.3
7/26/2021 11:10	WALL	DRYWALL	B	INTACT	WHITE	10	LIVING ROOM	1006	Negative	0	mg / cm ^2	0.02
7/26/2021 11:10	WALL	DRYWALL	C	INTACT	WHITE	10	LIVING ROOM	1006	Negative	0.01	mg / cm ^2	0.02
7/26/2021 11:11	WALL	DRYWALL	D	INTACT	WHITE	10	LIVING ROOM	1006	Negative	0	mg / cm ^2	0.02
7/26/2021 11:12	HEATER	METAL	A	INTACT	WHITE	10	LIVING ROOM	1006	Negative	0.01	mg / cm ^2	0.03
7/26/2021 11:13	WALL	DRYWALL	A	INTACT	WHITE	10	BATHROOM	1006	Negative	0.01	mg / cm ^2	0.02
7/26/2021 11:13	WALL	DRYWALL	B	INTACT	WHITE	10	BATHROOM	1006	Negative	0.02	mg / cm ^2	0.06
7/26/2021 11:13	WALL	DRYWALL	C	INTACT	WHITE	10	BATHROOM	1006	Negative	0	mg / cm ^2	0.02

XRF Readings
 Site: Bayshore Towers Apartments
 128 Perry Street
 Sandusky, OH 44870

Lead Risk Assessors:
 Charles Long / Joshua Fry

Time	Component	Substrate	Side	Condition	Color	Floor	Room	Apt. #	Results	PbC	Units	PbC Error
7/26/2021 11:13	WALL	DRYWALL	D	INTACT	WHITE	10	BATHROOM	1006	Negative	0.01	mg / cm ^2	0.02
7/26/2021 11:14	CEILING	DRYWALL		INTACT	WHITE	10	BATHROOM	1006	Negative	0	mg / cm ^2	0.02
7/26/2021 11:14	DOOR	WOOD	A	INTACT	WHITE	10	BATHROOM	1006	Negative	0	mg / cm ^2	0.02
7/26/2021 11:15	DOOR FRAME	METAL	A	INTACT	WHITE	10	BATHROOM	1006	Negative	0.01	mg / cm ^2	0.04
7/26/2021 11:15	DOOR FRAME	METAL	C	INTACT	WHITE	10	LIVING ROOM	1006	Negative	0	mg / cm ^2	0.02
7/26/2021 11:16	DOOR	WOOD	B	INTACT	WHITE	10	LIVING ROOM	1006	Negative	0	mg / cm ^2	0.02
7/26/2021 11:18	DOOR	WOOD	A	INTACT	GREEN	10	HALL	COMMON	Negative	0	mg / cm ^2	0.02
7/26/2021 11:18	DOOR FRAME	METAL	A	INTACT	GREEN	10	HALL	COMMON	Negative	0	mg / cm ^2	0.02
7/26/2021 11:25	WALL	DRYWALL	A	INTACT	WHITE	9	LIVING ROOM	903	Negative	0	mg / cm ^2	0.02
7/26/2021 11:26	WALL	DRYWALL	B	INTACT	WHITE	9	LIVING ROOM	903	Negative	0	mg / cm ^2	0.02
7/26/2021 11:26	WALL	DRYWALL	C	INTACT	WHITE	9	LIVING ROOM	903	Negative	0	mg / cm ^2	0.02
7/26/2021 11:26	WALL	DRYWALL	D	INTACT	WHITE	9	LIVING ROOM	903	Negative	0	mg / cm ^2	0.02
7/26/2021 11:27	CEILING	DRYWALL		INTACT	WHITE	9	LIVING ROOM	903	Negative	0	mg / cm ^2	0.02
7/26/2021 11:28	DOOR	WOOD	A	INTACT	WHITE	9	LIVING ROOM	903	Negative	0	mg / cm ^2	0.02
7/26/2021 11:28	DOOR FRAME	METAL	A	INTACT	WHITE	9	LIVING ROOM	903	Negative	0.01	mg / cm ^2	0.03
7/26/2021 11:29	DOOR FRAME	METAL	D	INTACT	WHITE	9	BEDROOM	903	Negative	0	mg / cm ^2	0.02
7/26/2021 11:29	WALL	DRYWALL	A	INTACT	WHITE	9	BEDROOM	903	Negative	0	mg / cm ^2	0.02
7/26/2021 11:30	WALL	DRYWALL	B	INTACT	WHITE	9	BEDROOM	903	Negative	0	mg / cm ^2	0.02
7/26/2021 11:30	WALL	DRYWALL	C	INTACT	WHITE	9	BEDROOM	903	Negative	0.6	mg / cm ^2	0.3
7/26/2021 11:30	WALL	DRYWALL	D	INTACT	WHITE	9	BEDROOM	903	Negative	0	mg / cm ^2	0.02
7/26/2021 11:31	CEILING	DRYWALL		INTACT	WHITE	9	BEDROOM	903	Negative	0	mg / cm ^2	0.02
7/26/2021 11:31	DOOR	WOOD	A	INTACT	WHITE	9	BEDROOM	903	Negative	0	mg / cm ^2	0.02
7/26/2021 11:32	DOOR TRIM	WOOD	A	INTACT	WHITE	9	BEDROOM	903	Negative	0	mg / cm ^2	0.02
7/26/2021 11:32	DOOR FRAME	METAL	A	INTACT	WHITE	9	BEDROOM	903	Negative	0	mg / cm ^2	0.02
7/26/2021 11:32	DOOR FRAME	METAL	C	INTACT	WHITE	9	BEDROOM	903	Negative	0	mg / cm ^2	0.02
7/26/2021 11:33	WALL	DRYWALL	A	INTACT	WHITE	9	BATHROOM	903	Negative	0	mg / cm ^2	0.02
7/26/2021 11:34	WALL	DRYWALL	B	INTACT	WHITE	9	BATHROOM	903	Negative	0	mg / cm ^2	0.02
7/26/2021 11:34	WALL	DRYWALL	C	INTACT	WHITE	9	BATHROOM	903	Negative	0.7	mg / cm ^2	0.3
7/26/2021 11:34	WALL	DRYWALL	D	INTACT	WHITE	9	BATHROOM	903	Negative	0	mg / cm ^2	0.02
7/26/2021 11:35	CEILING	DRYWALL		INTACT	WHITE	9	BATHROOM	903	Negative	0.01	mg / cm ^2	0.02
7/26/2021 11:38	CEILING	DRYWALL		INTACT	WHITE	9	LIVING ROOM	904	Negative	0	mg / cm ^2	0.02
7/26/2021 11:38	WALL	DRYWALL	A	INTACT	WHITE	9	LIVING ROOM	904	Negative	0	mg / cm ^2	0.02
7/26/2021 11:39	WALL	DRYWALL	B	INTACT	WHITE	9	LIVING ROOM	904	Negative	0	mg / cm ^2	0.02
7/26/2021 11:39	WALL	DRYWALL	C	INTACT	WHITE	9	LIVING ROOM	904	Negative	0	mg / cm ^2	0.02
7/26/2021 11:40	WALL	DRYWALL	D	INTACT	WHITE	9	LIVING ROOM	904	Negative	0	mg / cm ^2	0.02

XRF Readings
 Site: Bayshore Towers Apartments
 128 Perry Street
 Sandusky, OH 44870

Lead Risk Assessors:
 Charles Long / Joshua Fry

Time	Component	Substrate	Side	Condition	Color	Floor	Room	Apt. #	Results	PbC	Units	PbC Error
7/26/2021 11:40	HEATER	METAL	A	INTACT	WHITE	9	LIVING ROOM	904	Negative	0.01	mg / cm ^2	0.03
7/26/2021 11:41	DOOR	WOOD	D	INTACT	WHITE	9	LIVING ROOM	904	Negative	0	mg / cm ^2	0.02
7/26/2021 11:41	DOOR TRIM	WOOD	D	INTACT	WHITE	9	LIVING ROOM	904	Negative	0	mg / cm ^2	0.02
7/26/2021 11:42	DOOR TRIM	WOOD	B	INTACT	WHITE	9	BEDROOM	904	Negative	0	mg / cm ^2	0.02
7/26/2021 11:42	DOOR	WOOD	B	INTACT	WHITE	9	BEDROOM	904	Negative	0	mg / cm ^2	0.02
7/26/2021 11:43	WALL	DRYWALL	A	INTACT	WHITE	9	BEDROOM	904	Negative	0	mg / cm ^2	0.02
7/26/2021 11:43	WALL	DRYWALL	B	INTACT	WHITE	9	BEDROOM	904	Negative	0.5	mg / cm ^2	0.4
7/26/2021 11:44	WALL	DRYWALL	C	INTACT	WHITE	9	BEDROOM	904	Negative	0	mg / cm ^2	0.02
7/26/2021 11:44	WALL	DRYWALL	D	INTACT	WHITE	9	BEDROOM	904	Negative	0	mg / cm ^2	0.02
7/26/2021 11:44	CEILING	DRYWALL		INTACT	WHITE	9	BEDROOM	904	Negative	0	mg / cm ^2	0.02
7/26/2021 11:45	DOOR FRAME	METAL	B	INTACT	WHITE	9	BEDROOM	904	Negative	0.01	mg / cm ^2	0.02
7/26/2021 11:45	DOOR FRAME	METAL	C	INTACT	WHITE	9	BATHROOM	904	Negative	0	mg / cm ^2	0.02
7/26/2021 11:46	WALL	DRYWALL	A	INTACT	WHITE	9	BATHROOM	904	Negative	0	mg / cm ^2	0.02
7/26/2021 11:46	WALL	DRYWALL	B	INTACT	WHITE	9	BATHROOM	904	Negative	0	mg / cm ^2	0.02
7/26/2021 11:46	WALL	DRYWALL	C	INTACT	WHITE	9	BATHROOM	904	Negative	0	mg / cm ^2	0.02
7/26/2021 11:46	WALL	DRYWALL	D	INTACT	WHITE	9	BATHROOM	904	Negative	0	mg / cm ^2	0.02
7/26/2021 11:47	WALL	DRYWALL	D	INTACT	WHITE	9	BATHROOM	904	Negative	0	mg / cm ^2	0.02
7/26/2021 11:48	CEILING	DRYWALL		INTACT	WHITE	9	BATHROOM	904	Negative	0	mg / cm ^2	0.02
7/26/2021 11:54	CEILING	DRYWALL		INTACT	WHITE	8	LIVING ROOM	806	Negative	0	mg / cm ^2	0.02
7/26/2021 11:54	WALL	DRYWALL	A	INTACT	WHITE	8	LIVING ROOM	806	Negative	0	mg / cm ^2	0.02
7/26/2021 11:55	WALL	DRYWALL	B	INTACT	WHITE	8	LIVING ROOM	806	Negative	0	mg / cm ^2	0.02
7/26/2021 11:55	WALL	DRYWALL	C	INTACT	WHITE	8	LIVING ROOM	806	Negative	0	mg / cm ^2	0.02
7/26/2021 11:56	WALL	DRYWALL	D	INTACT	WHITE	8	LIVING ROOM	806	Negative	0	mg / cm ^2	0.02
7/26/2021 11:57	WALL	DRYWALL	A	INTACT	WHITE	8	BEDROOM	806	Negative	0	mg / cm ^2	0.02
7/26/2021 11:57	WALL	DRYWALL	B	INTACT	WHITE	8	BEDROOM	806	Negative	0	mg / cm ^2	0.02
7/26/2021 11:57	WALL	DRYWALL	C	INTACT	WHITE	8	BEDROOM	806	Negative	0	mg / cm ^2	0.02
7/26/2021 11:58	CEILING	DRYWALL		INTACT	WHITE	8	BEDROOM	806	Negative	0	mg / cm ^2	0.02
7/26/2021 11:59	WALL	DRYWALL	A	INTACT	WHITE	8	BATHROOM	806	Negative	0	mg / cm ^2	0.02
7/26/2021 11:59	WALL	DRYWALL	B	INTACT	WHITE	8	BATHROOM	806	Negative	0	mg / cm ^2	0.02
7/26/2021 11:59	WALL	DRYWALL	C	INTACT	WHITE	8	BATHROOM	806	Negative	0	mg / cm ^2	0.02
7/26/2021 12:00	WALL	DRYWALL	D	INTACT	WHITE	8	BATHROOM	806	Negative	0.01	mg / cm ^2	0.02
7/26/2021 12:00	CEILING	DRYWALL		INTACT	WHITE	8	BATHROOM	806	Negative	0	mg / cm ^2	0.02
7/26/2021 12:01	DOOR	WOOD	D	INTACT	WHITE	8	BATHROOM	806	Negative	0	mg / cm ^2	0.02
7/26/2021 12:02	DOOR FRAME	METAL	D	INTACT	WHITE	8	BATHROOM	806	Negative	0	mg / cm ^2	0.02
7/26/2021 12:04	DOOR FRAME	WOOD	B	INTACT	WHITE	8	BEDROOM	806	Negative	0	mg / cm ^2	0.02
7/26/2021 12:04	DOOR	WOOD	B	INTACT	WHITE	8	BEDROOM	806	Negative	0	mg / cm ^2	0.02

XRF Readings
 Site: Bayshore Towers Apartments
 128 Perry Street
 Sandusky, OH 44870

Lead Risk Assessors:
 Charles Long / Joshua Fry

Time	Component	Substrate	Side	Condition	Color	Floor	Room	Apt. #	Results	PbC	Units	PbC Error
7/26/2021 12:05	HEATER	METAL	A	INTACT	WHITE	8	BEDROOM	806	Negative	0.05	mg / cm ^2	0.15
7/26/2021 12:06	DOOR FRAME	METAL	C	INTACT	WHITE	8	LIVING ROOM	806	Negative	0	mg / cm ^2	0.02
7/26/2021 12:07	DOOR	WOOD	C	INTACT	WHITE	8	LIVING ROOM	806	Negative	0	mg / cm ^2	0.02
7/26/2021 12:09	WALL	DRYWALL	A	INTACT	WHITE	8	LIVING ROOM	809	Negative	0	mg / cm ^2	0.02
7/26/2021 12:10	WALL	DRYWALL	B	INTACT	WHITE	8	LIVING ROOM	809	Negative	0	mg / cm ^2	0.02
7/26/2021 12:10	WALL	DRYWALL	C	INTACT	WHITE	8	LIVING ROOM	809	Negative	0	mg / cm ^2	0.02
7/26/2021 12:11	WALL	DRYWALL	D	INTACT	WHITE	8	LIVING ROOM	809	Negative	0	mg / cm ^2	0.02
7/26/2021 12:11	CEILING	DRYWALL		INTACT	WHITE	8	LIVING ROOM	809	Negative	0	mg / cm ^2	0.02
7/26/2021 12:12	CEILING	DRYWALL		INTACT	WHITE	8	BEDROOM	809	Negative	0	mg / cm ^2	0.02
7/26/2021 12:13	WALL	DRYWALL	A	INTACT	WHITE	8	BEDROOM	809	Negative	0	mg / cm ^2	0.02
7/26/2021 12:13	WALL	DRYWALL	B	INTACT	WHITE	8	BEDROOM	809	Negative	0	mg / cm ^2	0.02
7/26/2021 12:14	WALL	DRYWALL	C	INTACT	WHITE	8	BEDROOM	809	Negative	0	mg / cm ^2	0.02
7/26/2021 12:14	WALL	DRYWALL	D	INTACT	WHITE	8	BEDROOM	809	Negative	0	mg / cm ^2	0.02
7/26/2021 12:14	WALL	DRYWALL	D	INTACT	WHITE	8	BEDROOM	809	Negative	0	mg / cm ^2	0.02
7/26/2021 12:15	WALL	DRYWALL	A	INTACT	WHITE	8	BATHROOM	809	Negative	0.02	mg / cm ^2	0.07
7/26/2021 12:15	WALL	DRYWALL	B	INTACT	WHITE	8	BATHROOM	809	Negative	0	mg / cm ^2	0.02
7/26/2021 12:15	WALL	DRYWALL	C	INTACT	WHITE	8	BATHROOM	809	Negative	0.01	mg / cm ^2	0.04
7/26/2021 12:16	WALL	DRYWALL	D	INTACT	WHITE	8	BATHROOM	809	Negative	0.02	mg / cm ^2	0.03
7/26/2021 12:16	CEILING	DRYWALL		INTACT	WHITE	8	BATHROOM	809	Negative	0	mg / cm ^2	0.02
7/26/2021 12:17	DOOR FRAME	METAL	C	INTACT	WHITE	8	BATHROOM	809	Negative	0	mg / cm ^2	0.02
7/26/2021 12:18	DOOR	WOOD	C	INTACT	WHITE	8	BATHROOM	809	Negative	0	mg / cm ^2	0.02
7/26/2021 12:19	HEATER	METAL	C	INTACT	WHITE	8	LIVING ROOM	809	Negative	0.08	mg / cm ^2	0.23
7/26/2021 12:20	DOOR	WOOD	A	INTACT	WHITE	8	LIVING ROOM	809	Negative	0	mg / cm ^2	0.02
7/26/2021 12:21	DOOR FRAME	METAL	A	INTACT	WHITE	8	LIVING ROOM	809	Negative	0	mg / cm ^2	0.02
7/26/2021 12:24	WALL	DRYWALL	A	INTACT	WHITE	8	LIVING ROOM	709	Negative	0	mg / cm ^2	0.02
7/26/2021 12:24	WALL	DRYWALL	B	INTACT	WHITE	8	LIVING ROOM	709	Negative	0	mg / cm ^2	0.02
7/26/2021 12:24	WALL	DRYWALL	C	INTACT	WHITE	8	LIVING ROOM	709	Negative	0	mg / cm ^2	0.02
7/26/2021 12:25	WALL	DRYWALL	D	INTACT	WHITE	8	LIVING ROOM	709	Negative	0	mg / cm ^2	0.02
7/26/2021 12:25	CEILING	DRYWALL		INTACT	WHITE	8	LIVING ROOM	709	Negative	0	mg / cm ^2	0.02
7/26/2021 12:27	CEILING	DRYWALL		INTACT	WHITE	7	BEDROOM	709	Negative	0	mg / cm ^2	0.02
7/26/2021 12:27	WALL	DRYWALL	A	INTACT	WHITE	7	BEDROOM	709	Negative	0	mg / cm ^2	0.02
7/26/2021 12:28	WALL	DRYWALL	B	INTACT	WHITE	7	BEDROOM	709	Negative	0	mg / cm ^2	0.02
7/26/2021 12:28	WALL	DRYWALL	C	INTACT	WHITE	7	BEDROOM	709	Negative	0	mg / cm ^2	0.02
7/26/2021 12:28	WALL	DRYWALL	D	INTACT	WHITE	7	BEDROOM	709	Negative	0	mg / cm ^2	0.02
7/26/2021 12:29	WALL	DRYWALL	A	INTACT	WHITE	7	BATHROOM	709	Negative	0	mg / cm ^2	0.02

XRF Readings
 Site: Bayshore Towers Apartments
 128 Perry Street
 Sandusky, OH 44870

Lead Risk Assessors:
 Charles Long / Joshua Fry

Time	Component	Substrate	Side	Condition	Color	Floor	Room	Apt. #	Results	PbC	Units	PbC Error
7/26/2021 12:29	WALL	DRYWALL	B	INTACT	WHITE	7	BATHROOM	709	Negative	0.01	mg / cm ^2	0.03
7/26/2021 12:30	WALL	DRYWALL	C	INTACT	WHITE	7	BATHROOM	709	Negative	0.01	mg / cm ^2	0.03
7/26/2021 12:30	WALL	DRYWALL	D	INTACT	WHITE	7	BATHROOM	709	Null	0	mg / cm ^2	0.04
7/26/2021 12:30	WALL	DRYWALL	D	INTACT	WHITE	7	BATHROOM	709	Negative	0.01	mg / cm ^2	0.02
7/26/2021 12:31	CEILING	DRYWALL		INTACT	WHITE	7	BATHROOM	709	Negative	0.02	mg / cm ^2	0.02
7/26/2021 12:31	CEILING	DRYWALL		INTACT	WHITE	7	BATHROOM	709	Negative	0.01	mg / cm ^2	0.02
7/26/2021 12:32	DOOR FRAME	METAL	C	INTACT	WHITE	7	BATHROOM	709	Negative	0	mg / cm ^2	0.02
7/26/2021 12:32	DOOR	WOOD	C	INTACT	WHITE	7	BATHROOM	709	Negative	0	mg / cm ^2	0.02
7/26/2021 12:33	HEATER	METAL	C	INTACT	WHITE	7	BEDROOM	709	Negative	0.02	mg / cm ^2	0.04
7/26/2021 12:34	DOOR	METAL	A	INTACT	WHITE	7	LIVING ROOM	709	Negative	0	mg / cm ^2	0.02
7/26/2021 12:34	DOOR FRAME	METAL	A	INTACT	WHITE	7	LIVING ROOM	709	Negative	0	mg / cm ^2	0.02
7/26/2021 12:35	DOOR FRAME	METAL	A	INTACT	WHITE	7	LIVING ROOM	709	Negative	0	mg / cm ^2	0.02
7/26/2021 12:38	DOOR FRAME	METAL	C	INTACT	WHITE	7	LIVING ROOM	708	Negative	0	mg / cm ^2	0.02
7/26/2021 12:38	DOOR	METAL	C	INTACT	WHITE	7	LIVING ROOM	708	Negative	0	mg / cm ^2	0.02
7/26/2021 12:38	CEILING	DRYWALL		INTACT	WHITE	7	LIVING ROOM	708	Negative	0	mg / cm ^2	0.02
7/26/2021 12:39	WALL	DRYWALL	A	INTACT	WHITE	7	LIVING ROOM	708	Negative	0	mg / cm ^2	0.02
7/26/2021 12:39	WALL	DRYWALL	B	INTACT	WHITE	7	LIVING ROOM	708	Negative	0	mg / cm ^2	0.02
7/26/2021 12:39	WALL	DRYWALL	C	INTACT	WHITE	7	LIVING ROOM	708	Negative	0	mg / cm ^2	0.02
7/26/2021 12:40	WALL	DRYWALL	D	INTACT	WHITE	7	LIVING ROOM	708	Negative	0	mg / cm ^2	0.02
7/26/2021 12:40	CEILING	DRYWALL		INTACT	WHITE	7	BEDROOM	708	Negative	0	mg / cm ^2	0.02
7/26/2021 12:41	WALL	DRYWALL	A	INTACT	WHITE	7	BEDROOM	708	Negative	0	mg / cm ^2	0.02
7/26/2021 12:41	WALL	DRYWALL	B	INTACT	WHITE	7	BEDROOM	708	Negative	0	mg / cm ^2	0.02
7/26/2021 12:42	WALL	DRYWALL	C	INTACT	WHITE	7	BEDROOM	708	Negative	0	mg / cm ^2	0.02
7/26/2021 12:42	WALL	DRYWALL	D	INTACT	WHITE	7	BEDROOM	708	Negative	0	mg / cm ^2	0.02
7/26/2021 12:43	WALL	DRYWALL	A	INTACT	WHITE	7	BATHROOM	708	Negative	0.01	mg / cm ^2	0.02
7/26/2021 12:43	WALL	DRYWALL	B	INTACT	WHITE	7	BATHROOM	708	Negative	0	mg / cm ^2	0.02
7/26/2021 12:43	WALL	DRYWALL	C	INTACT	WHITE	7	BATHROOM	708	Negative	0	mg / cm ^2	0.02
7/26/2021 12:44	WALL	DRYWALL	D	INTACT	WHITE	7	BATHROOM	708	Negative	0	mg / cm ^2	0.02
7/26/2021 12:44	CEILING	DRYWALL		INTACT	WHITE	7	BATHROOM	708	Negative	0.01	mg / cm ^2	0.03
7/26/2021 12:45	DOOR	WOOD	A	INTACT	WHITE	7	BATHROOM	708	Negative	0	mg / cm ^2	0.02
7/26/2021 12:45	DOOR FRAME	METAL	A	INTACT	WHITE	7	BATHROOM	708	Negative	0	mg / cm ^2	0.02
7/26/2021 12:46	HEATER	METAL	A	INTACT	WHITE	7	BEDROOM	708	Negative	0.01	mg / cm ^2	0.02
7/26/2021 12:47	DOOR FRAME	WOOD	D	INTACT	WHITE	7	BEDROOM	708	Negative	0	mg / cm ^2	0.02
7/26/2021 12:50	CALCHECK								Negative	0.9	mg / cm ^2	0.1
7/26/2021 12:51	CALCHECK								Positive	1.1	mg / cm ^2	0.1

XRF Readings
 Site: Bayshore Towers Apartments
 128 Perry Street
 Sandusky, OH 44870

Lead Risk Assessors:
 Charles Long / Joshua Fry

Time	Component	Substrate	Side	Condition	Color	Floor	Room	Apt. #	Results	PbC	Units	PbC Error
7/26/2021 12:51	CALCHECK								Null	1	mg / cm ^2	0.1
7/26/2021 13:43	WALL	DRYWALL	A	INTACT	WHITE	6	LIVING ROOM	603	Negative	0	mg / cm ^2	0.02
7/26/2021 13:44	WALL	DRYWALL	B	INTACT	WHITE	6	LIVING ROOM	603	Negative	0	mg / cm ^2	0.02
7/26/2021 13:44	WALL	DRYWALL	C	INTACT	WHITE	6	LIVING ROOM	603	Negative	0	mg / cm ^2	0.02
7/26/2021 13:44	WALL	DRYWALL	D	INTACT	WHITE	6	LIVING ROOM	603	Negative	0	mg / cm ^2	0.02
7/26/2021 13:45	CEILING	DRYWALL		INTACT	WHITE	6	LIVING ROOM	603	Negative	0	mg / cm ^2	0.02
7/26/2021 13:45	CEILING	DRYWALL		INTACT	WHITE	6	BEDROOM	603	Negative	0	mg / cm ^2	0.02
7/26/2021 13:46	WALL	DRYWALL	A	INTACT	WHITE	6	BEDROOM	603	Negative	0	mg / cm ^2	0.02
7/26/2021 13:46	WALL	DRYWALL	B	INTACT	WHITE	6	BEDROOM	603	Negative	0	mg / cm ^2	0.02
7/26/2021 13:46	WALL	DRYWALL	C	INTACT	WHITE	6	BEDROOM	603	Negative	0	mg / cm ^2	0.02
7/26/2021 13:47	WALL	DRYWALL	D	INTACT	WHITE	6	BEDROOM	603	Negative	0	mg / cm ^2	0.02
7/26/2021 13:48	CEILING	DRYWALL		INTACT	WHITE	6	BATHROOM	603	Negative	0.01	mg / cm ^2	0.02
7/26/2021 13:48	WALL	DRYWALL	A	INTACT	WHITE	6	BATHROOM	603	Negative	0.01	mg / cm ^2	0.02
7/26/2021 13:48	WALL	DRYWALL	B	INTACT	WHITE	6	BATHROOM	603	Negative	0.18	mg / cm ^2	0.65
7/26/2021 13:48	WALL	DRYWALL	C	INTACT	WHITE	6	BATHROOM	603	Negative	0	mg / cm ^2	0.02
7/26/2021 13:49	WALL	DRYWALL	D	INTACT	WHITE	6	BATHROOM	603	Negative	0.01	mg / cm ^2	0.03
7/26/2021 13:49	DOOR	WOOD	C	INTACT	WHITE	6	BATHROOM	603	Negative	0	mg / cm ^2	0.02
7/26/2021 13:50	DOOR FRAME	METAL	C	INTACT	WHITE	6	BATHROOM	603	Negative	0	mg / cm ^2	0.02
7/26/2021 13:51	HEATER	METAL	C	INTACT	WHITE	6	LIVING ROOM	603	Negative	0.01	mg / cm ^2	0.03
7/26/2021 13:51	DOOR	METAL	A	INTACT	WHITE	6	LIVING ROOM	603	Negative	0	mg / cm ^2	0.07
7/26/2021 13:52	DOOR FRAME	METAL	A	INTACT	WHITE	6	LIVING ROOM	603	Negative	0	mg / cm ^2	0.02
7/26/2021 13:53	DOOR FRAME	METAL	C	INTACT	WHITE	6	LIVING ROOM	609	Negative	0	mg / cm ^2	0.02
7/26/2021 13:53	DOOR	METAL	C	INTACT	WHITE	6	LIVING ROOM	609	Negative	0	mg / cm ^2	0.02
7/26/2021 13:54	CEILING	DRYWALL		INTACT	WHITE	6	LIVING ROOM	609	Negative	0	mg / cm ^2	0.02
7/26/2021 13:55	WALL	DRYWALL	A	INTACT	WHITE	6	LIVING ROOM	609	Negative	0	mg / cm ^2	0.02
7/26/2021 13:55	WALL	DRYWALL	B	INTACT	WHITE	6	LIVING ROOM	609	Negative	0	mg / cm ^2	0.02
7/26/2021 13:55	WALL	DRYWALL	C	INTACT	WHITE	6	LIVING ROOM	609	Negative	0	mg / cm ^2	0.02
7/26/2021 13:56	WALL	DRYWALL	D	INTACT	WHITE	6	LIVING ROOM	609	Negative	0	mg / cm ^2	0.02
7/26/2021 13:56	WALL	DRYWALL	A	INTACT	WHITE	6	BEDROOM	609	Negative	0	mg / cm ^2	0.02
7/26/2021 13:56	WALL	DRYWALL	A	INTACT	WHITE	6	BEDROOM	609	Negative	0	mg / cm ^2	0.02
7/26/2021 13:57	WALL	DRYWALL	B	INTACT	WHITE	6	BEDROOM	609	Negative	0	mg / cm ^2	0.02
7/26/2021 13:57	WALL	DRYWALL	C	INTACT	WHITE	6	BEDROOM	609	Negative	0	mg / cm ^2	0.02
7/26/2021 13:57	WALL	DRYWALL	D	INTACT	WHITE	6	BEDROOM	609	Negative	0	mg / cm ^2	0.02
7/26/2021 13:58	CEILING	DRYWALL		INTACT	WHITE	6	BEDROOM	609	Negative	0	mg / cm ^2	0.02
7/26/2021 13:58	CEILING	DRYWALL		INTACT	WHITE	6	BATHROOM	609	Negative	0.01	mg / cm ^2	0.02

XRF Readings
 Site: Bayshore Towers Apartments
 128 Perry Street
 Sandusky, OH 44870

Lead Risk Assessors:
 Charles Long / Joshua Fry

Time	Component	Substrate	Side	Condition	Color	Floor	Room	Apt. #	Results	PbC	Units	PbC Error
7/26/2021 13:59	WALL	DRYWALL	A	INTACT	WHITE	6	BATHROOM	609	Negative	0	mg / cm ^2	0.02
7/26/2021 13:59	WALL	DRYWALL	B	INTACT	WHITE	6	BATHROOM	609	Negative	0.01	mg / cm ^2	0.02
7/26/2021 13:59	WALL	DRYWALL	C	INTACT	WHITE	6	BATHROOM	609	Negative	0	mg / cm ^2	0.02
7/26/2021 13:59	WALL	DRYWALL	D	INTACT	WHITE	6	BATHROOM	609	Negative	0.01	mg / cm ^2	0.02
7/26/2021 14:00	DOOR	WOOD	C	INTACT	WHITE	6	BATHROOM	609	Negative	0	mg / cm ^2	0.02
7/26/2021 14:00	DOOR FRAME	METAL	C	INTACT	WHITE	6	BATHROOM	609	Negative	0	mg / cm ^2	0.02
7/26/2021 14:01	HEATER	METAL	C	INTACT	WHITE	6	BEDROOM	609	Negative	0.03	mg / cm ^2	0.1
7/26/2021 14:02	DOOR	METAL	A	INTACT	WHITE	6	LIVING ROOM	609	Negative	0	mg / cm ^2	0.02
7/26/2021 14:02	DOOR FRAME	METAL	A	INTACT	WHITE	6	LIVING ROOM	609	Negative	0	mg / cm ^2	0.02
7/26/2021 14:02	DOOR FRAME	WOOD	B	INTACT	WHITE	6	LIVING ROOM	609	Negative	0	mg / cm ^2	0.02
7/26/2021 14:07	ELEV DOOR	METAL	C	INTACT	BLUE	5	HALL	COMMON	Negative	0.03	mg / cm ^2	0.03
7/26/2021 14:07	ELEV DOOR FRAME	METAL	C	INTACT	BLUE	5	HALL	COMMON	Negative	0.02	mg / cm ^2	0.02
7/26/2021 14:09	DOOR	METAL	C	INTACT	BLUE	5	LIVING ROOM	501	Negative	0	mg / cm ^2	0.02
7/26/2021 14:09	DOOR FRAME	METAL	C	INTACT	BLUE	5	LIVING ROOM	501	Negative	0	mg / cm ^2	0.02
7/26/2021 14:10	DOOR FRAME	METAL	A	INTACT	WHITE	5	LIVING ROOM	501	Negative	0	mg / cm ^2	0.02
7/26/2021 14:11	DOOR	METAL	A	INTACT	WHITE	5	LIVING ROOM	501	Negative	0	mg / cm ^2	0.02
7/26/2021 14:11	WALL	DRYWALL	A	INTACT	WHITE	5	LIVING ROOM	501	Negative	0	mg / cm ^2	0.02
7/26/2021 14:12	WALL	DRYWALL	B	INTACT	WHITE	5	LIVING ROOM	501	Negative	0.01	mg / cm ^2	0.02
7/26/2021 14:12	WALL	DRYWALL	C	INTACT	WHITE	5	LIVING ROOM	501	Negative	0	mg / cm ^2	0.02
7/26/2021 14:12	WALL	DRYWALL	D	INTACT	WHITE	5	LIVING ROOM	501	Negative	0	mg / cm ^2	0.02
7/26/2021 14:13	CEILING	DRYWALL		INTACT	WHITE	5	LIVING ROOM	501	Negative	0	mg / cm ^2	0.02
7/26/2021 14:13	DOOR	WOOD	D	INTACT	WHITE	5	LIVING ROOM	501	Negative	0	mg / cm ^2	0.02
7/26/2021 14:14	CEILING	DRYWALL		INTACT	WHITE	5	BEDROOM	501	Negative	0	mg / cm ^2	0.02
7/26/2021 14:14	WALL	DRYWALL	A	INTACT	WHITE	5	BEDROOM	501	Negative	0	mg / cm ^2	0.02
7/26/2021 14:14	WALL	DRYWALL	B	INTACT	WHITE	5	BEDROOM	501	Negative	0	mg / cm ^2	0.02
7/26/2021 14:15	WALL	DRYWALL	C	INTACT	WHITE	5	BEDROOM	501	Negative	0	mg / cm ^2	0.02
7/26/2021 14:15	WALL	DRYWALL	D	INTACT	WHITE	5	BEDROOM	501	Negative	0	mg / cm ^2	0.02
7/26/2021 14:16	WALL	DRYWALL	A	INTACT	WHITE	5	BATHROOM	501	Negative	0.02	mg / cm ^2	0.06
7/26/2021 14:16	WALL	DRYWALL	B	INTACT	WHITE	5	BATHROOM	501	Negative	0	mg / cm ^2	0.02
7/26/2021 14:16	WALL	DRYWALL	C	INTACT	WHITE	5	BATHROOM	501	Negative	0.01	mg / cm ^2	0.02
7/26/2021 14:17	WALL	DRYWALL	D	INTACT	WHITE	5	BATHROOM	501	Negative	0.04	mg / cm ^2	0.03
7/26/2021 14:17	CEILING	DRYWALL		INTACT	WHITE	5	BATHROOM	501	Negative	0	mg / cm ^2	0.02
7/26/2021 14:18	HEATER	METAL	C	INTACT	WHITE	5	BEDROOM	501	Negative	0.01	mg / cm ^2	0.04
7/26/2021 14:19	DOOR FRAME	WOOD	A	INTACT	WHITE	5	BEDROOM	501	Negative	0	mg / cm ^2	0.02
7/26/2021 14:22	WALL	DRYWALL	A	INTACT	WHITE	5	LIVING ROOM	502	Negative	0	mg / cm ^2	0.02

XRF Readings
 Site: Bayshore Towers Apartments
 128 Perry Street
 Sandusky, OH 44870

Lead Risk Assessors:
 Charles Long / Joshua Fry

Time	Component	Substrate	Side	Condition	Color	Floor	Room	Apt. #	Results	PbC	Units	PbC Error
7/26/2021 14:22	WALL	DRYWALL	B	INTACT	WHITE	5	LIVING ROOM	502	Negative	0	mg / cm ^2	0.02
7/26/2021 14:23	WALL	DRYWALL	C	INTACT	WHITE	5	LIVING ROOM	502	Negative	0	mg / cm ^2	0.02
7/26/2021 14:23	WALL	DRYWALL	D	INTACT	WHITE	5	LIVING ROOM	502	Negative	0	mg / cm ^2	0.02
7/26/2021 14:23	CEILING	DRYWALL		INTACT	WHITE	5	LIVING ROOM	502	Negative	0	mg / cm ^2	0.02
7/26/2021 14:24	CEILING	DRYWALL		INTACT	WHITE	5	BEDROOM	502	Negative	0	mg / cm ^2	0.02
7/26/2021 14:25	WALL	DRYWALL	A	INTACT	WHITE	5	BEDROOM	502	Negative	0	mg / cm ^2	0.02
7/26/2021 14:25	WALL	DRYWALL	B	INTACT	WHITE	5	BEDROOM	502	Negative	0	mg / cm ^2	0.02
7/26/2021 14:25	WALL	DRYWALL	C	INTACT	WHITE	5	BEDROOM	502	Negative	0	mg / cm ^2	0.02
7/26/2021 14:25	WALL	DRYWALL	D	INTACT	WHITE	5	BEDROOM	502	Negative	0	mg / cm ^2	0.02
7/26/2021 14:26	WALL	DRYWALL	A	INTACT	WHITE	5	BATHROOM	502	Negative	0	mg / cm ^2	0.02
7/26/2021 14:26	WALL	DRYWALL	B	INTACT	WHITE	5	BATHROOM	502	Negative	0	mg / cm ^2	0.02
7/26/2021 14:26	WALL	DRYWALL	C	INTACT	WHITE	5	BATHROOM	502	Negative	0	mg / cm ^2	0.02
7/26/2021 14:27	WALL	DRYWALL	D	INTACT	WHITE	5	BATHROOM	502	Negative	0	mg / cm ^2	0.02
7/26/2021 14:27	CEILING	DRYWALL		INTACT	WHITE	5	BATHROOM	502	Negative	0	mg / cm ^2	0.02
7/26/2021 14:27	DOOR	WOOD	A	INTACT	WHITE	5	BATHROOM	502	Negative	0	mg / cm ^2	0.02
7/26/2021 14:28	DOOR FRAME	WOOD	A	INTACT	WHITE	5	BATHROOM	502	Negative	0	mg / cm ^2	0.02
7/26/2021 14:29	HEATER	WOOD	A	INTACT	WHITE	5	BEDROOM	502	Negative	0.01	mg / cm ^2	0.04
7/26/2021 14:30	DOOR	METAL	C	INTACT	WHITE	5	BEDROOM	502	Negative	0	mg / cm ^2	0.02
7/26/2021 14:30	DOOR FRAME	METAL	C	INTACT	WHITE	5	BEDROOM	502	Negative	0	mg / cm ^2	0.02
7/26/2021 14:31	DOOR FRAME	WOOD	B	INTACT	WHITE	5	BEDROOM	502	Negative	0	mg / cm ^2	0.02
7/26/2021 14:31	DOOR	WOOD	B	INTACT	WHITE	5	BEDROOM	502	Negative	0	mg / cm ^2	0.02
7/26/2021 14:34	HEATER	METAL	A	INTACT	BLUE	5	HALL	COMMON	Negative	0.01	mg / cm ^2	0.02
7/26/2021 14:34	PIPE	METAL	A	INTACT	WHITE	5	HALL	COMMON	Negative	0	mg / cm ^2	0.02
7/26/2021 14:36	CALCHECK								Null	1.1	mg / cm ^2	0.5
7/26/2021 14:36	CALCHECK								Positive	1.1	mg / cm ^2	0.1
7/26/2021 14:37	CALCHECK								Positive	1.1	mg / cm ^2	0.1
7/26/2021 14:37	CALCHECK								Positive	1	mg / cm ^2	0.1
7/27/2021 9:23	CALCHECK								Positive	1	mg / cm ^2	0.1
7/27/2021 9:24	CALCHECK								Positive	1	mg / cm ^2	0.1
7/27/2021 9:24	CALCHECK								Positive	1	mg / cm ^2	0.1
7/27/2021 9:29	WALL	DRYWALL	A	INTACT	WHITE	4	LIVING ROOM	403	Negative	0	mg / cm ^2	0.02
7/27/2021 9:29	WALL	DRYWALL	B	INTACT	WHITE	4	LIVING ROOM	403	Negative	0.01	mg / cm ^2	0.02
7/27/2021 9:30	WALL	DRYWALL	C	INTACT	WHITE	4	LIVING ROOM	403	Negative	0	mg / cm ^2	0.02
7/27/2021 9:30	WALL	DRYWALL	D	INTACT	WHITE	4	LIVING ROOM	403	Negative	0	mg / cm ^2	0.02
7/27/2021 9:31	HEATER	METAL	C	INTACT	WHITE	4	LIVING ROOM	403	Negative	0.01	mg / cm ^2	0.04

XRF Readings
 Site: Bayshore Towers Apartments
 128 Perry Street
 Sandusky, OH 44870

Lead Risk Assessors:
 Charles Long / Joshua Fry

Time	Component	Substrate	Side	Condition	Color	Floor	Room	Apt. #	Results	PbC	Units	PbC Error
7/27/2021 9:31	DOOR	METAL	A	INTACT	WHITE	4	LIVING ROOM	403	Negative	0	mg / cm ^2	0.02
7/27/2021 9:31	DOOR FRAME	METAL	A	INTACT	WHITE	4	LIVING ROOM	403	Negative	0.01	mg / cm ^2	0.03
7/27/2021 9:32	DOOR FRAME	WOOD	D	INTACT	WHITE	4	LIVING ROOM	403	Negative	0	mg / cm ^2	0.02
7/27/2021 9:32	DOOR	WOOD	D	INTACT	WHITE	4	LIVING ROOM	403	Negative	0	mg / cm ^2	0.02
7/27/2021 9:32	CEILING	DRYWALL		INTACT	WHITE	4	LIVING ROOM	403	Negative	0	mg / cm ^2	0.02
7/27/2021 9:33	WALL	DRYWALL	D	INTACT	WHITE	4	BEDROOM	403	Negative	0	mg / cm ^2	0.02
7/27/2021 9:34	WALL	DRYWALL	A	INTACT	WHITE	4	BEDROOM	403	Negative	0	mg / cm ^2	0.02
7/27/2021 9:34	WALL	DRYWALL	B	INTACT	WHITE	4	BEDROOM	403	Negative	0	mg / cm ^2	0.02
7/27/2021 9:34	WALL	DRYWALL	C	INTACT	WHITE	4	BEDROOM	403	Negative	0	mg / cm ^2	0.02
7/27/2021 9:35	CEILING	DRYWALL		INTACT	WHITE	4	BEDROOM	403	Negative	0	mg / cm ^2	0.02
7/27/2021 9:36	WINDOW	METAL	C	INTACT	BLACK	4	BEDROOM	403	Negative	0	mg / cm ^2	0.02
7/27/2021 9:37	CEILING	DRYWALL		INTACT	WHITE	4	BATHROOM	403	Negative	0.01	mg / cm ^2	0.02
7/27/2021 9:38	WALL	DRYWALL	A	INTACT	WHITE	4	BATHROOM	403	Negative	0.01	mg / cm ^2	0.03
7/27/2021 9:38	WALL	DRYWALL	B	INTACT	WHITE	4	BATHROOM	403	Negative	0.02	mg / cm ^2	0.02
7/27/2021 9:38	WALL	DRYWALL	C	INTACT	WHITE	4	BATHROOM	403	Negative	0.01	mg / cm ^2	0.02
7/27/2021 9:38	WALL	DRYWALL	D	INTACT	WHITE	4	BATHROOM	403	Negative	0.03	mg / cm ^2	0.08
7/27/2021 9:39	DOOR	WOOD	C	INTACT	WHITE	4	BATHROOM	403	Negative	0	mg / cm ^2	0.02
7/27/2021 9:40	DOOR FRAME	METAL	C	INTACT	WHITE	4	BATHROOM	403	Negative	0.02	mg / cm ^2	0.03
7/27/2021 9:41	DOOR FRAME	WOOD	A	INTACT	WHITE	4	BEDROOM	403	Negative	0	mg / cm ^2	0.02
7/27/2021 9:41	DOOR FRAME	WOOD	A	INTACT	WHITE	4	BEDROOM	403	Negative	0	mg / cm ^2	0.02
7/27/2021 9:49	WALL	DRYWALL	A	INTACT	WHITE	2	LIVING ROOM	204	Negative	0	mg / cm ^2	0.02
7/27/2021 9:49	WALL	DRYWALL	B	INTACT	WHITE	2	LIVING ROOM	204	Negative	0	mg / cm ^2	0.02
7/27/2021 9:49	WALL	DRYWALL	C	INTACT	WHITE	2	LIVING ROOM	204	Negative	0	mg / cm ^2	0.02
7/27/2021 9:49	WALL	DRYWALL	D	INTACT	WHITE	2	LIVING ROOM	204	Negative	0	mg / cm ^2	0.02
7/27/2021 9:50	CEILING	DRYWALL		INTACT	WHITE	2	LIVING ROOM	204	Negative	0	mg / cm ^2	0.02
7/27/2021 9:51	DOOR	METAL	C	INTACT	WHITE	2	LIVING ROOM	204	Negative	0	mg / cm ^2	0.02
7/27/2021 9:51	DOOR FRAME	METAL	C	INTACT	WHITE	2	LIVING ROOM	204	Negative	0	mg / cm ^2	0.02
7/27/2021 9:52	DOOR FRAME	WOOD	D	INTACT	WHITE	2	LIVING ROOM	204	Negative	0	mg / cm ^2	0.02
7/27/2021 9:52	DOOR	WOOD	D	INTACT	WHITE	2	LIVING ROOM	204	Negative	0	mg / cm ^2	0.02
7/27/2021 9:52	DOOR	WOOD	D	INTACT	WHITE	2	LIVING ROOM	204	Negative	0	mg / cm ^2	0.02
7/27/2021 9:53	HEATER	METAL	A	INTACT	WHITE	2	LIVING ROOM	204	Negative	0.01	mg / cm ^2	0.03
7/27/2021 9:54	WALL	DRYWALL	A	INTACT	WHITE	2	BEDROOM	204	Negative	0	mg / cm ^2	0.02
7/27/2021 9:54	WALL	DRYWALL	B	INTACT	WHITE	2	BEDROOM	204	Negative	0	mg / cm ^2	0.02
7/27/2021 9:55	WALL	DRYWALL	C	INTACT	WHITE	2	BEDROOM	204	Negative	0	mg / cm ^2	0.02
7/27/2021 9:55	WALL	DRYWALL	D	INTACT	WHITE	2	BEDROOM	204	Negative	0	mg / cm ^2	0.02

XRF Readings
 Site: Bayshore Towers Apartments
 128 Perry Street
 Sandusky, OH 44870

Lead Risk Assessors:
 Charles Long / Joshua Fry

Time	Component	Substrate	Side	Condition	Color	Floor	Room	Apt. #	Results	PbC	Units	PbC Error
7/27/2021 9:55	CEILING	DRYWALL		INTACT	WHITE	2	BEDROOM	204	Negative	0	mg / cm ^2	0.02
7/27/2021 9:56	DOOR FRAME	WOOD	B	INTACT	WHITE	2	BEDROOM	204	Negative	0	mg / cm ^2	0.02
7/27/2021 9:56	DOOR	WOOD	B	INTACT	WHITE	2	BEDROOM	204	Negative	0	mg / cm ^2	0.02
7/27/2021 9:57	DOOR	WOOD	A	INTACT	WHITE	2	BATHROOM	204	Negative	0	mg / cm ^2	0.02
7/27/2021 9:57	DOOR FRAME	WOOD	A	INTACT	WHITE	2	BATHROOM	204	Negative	0	mg / cm ^2	0.02
7/27/2021 9:58	CEILING	DRYWALL		INTACT	WHITE	2	BATHROOM	204	Negative	0	mg / cm ^2	0.02
7/27/2021 9:58	WALL	DRYWALL	A	INTACT	WHITE	2	BATHROOM	204	Negative	0	mg / cm ^2	0.02
7/27/2021 9:59	WALL	DRYWALL	B	INTACT	WHITE	2	BATHROOM	204	Negative	0	mg / cm ^2	0.02
7/27/2021 9:59	WALL	DRYWALL	C	INTACT	WHITE	2	BATHROOM	204	Negative	0	mg / cm ^2	0.02
7/27/2021 9:59	WALL	DRYWALL	D	INTACT	WHITE	2	BATHROOM	204	Negative	0	mg / cm ^2	0.02
7/27/2021 10:05	CALCHECK								Positive	1.1	mg / cm ^2	0.1
7/27/2021 10:05	CALCHECK								Positive	1.1	mg / cm ^2	0.1
7/27/2021 10:05	CALCHECK								Positive	1.1	mg / cm ^2	0.1
7/27/2021 10:10	WALL	DRYWALL	A	INTACT	WHITE	3	LIVING ROOM	306	Negative	0	mg / cm ^2	0.02
7/27/2021 10:10	WALL	DRYWALL	B	INTACT	WHITE	3	LIVING ROOM	306	Negative	0	mg / cm ^2	0.02
7/27/2021 10:11	WALL	DRYWALL	C	INTACT	WHITE	3	LIVING ROOM	306	Negative	0	mg / cm ^2	0.02
7/27/2021 10:11	WALL	DRYWALL	D	INTACT	WHITE	3	LIVING ROOM	306	Negative	0	mg / cm ^2	0.02
7/27/2021 10:11	CEILING	DRYWALL		INTACT	WHITE	3	LIVING ROOM	306	Negative	0	mg / cm ^2	0.02
7/27/2021 10:12	DOOR	METAL	C	INTACT	WHITE	3	LIVING ROOM	306	Negative	0	mg / cm ^2	0.02
7/27/2021 10:12	DOOR FRAME	METAL	C	INTACT	WHITE	3	LIVING ROOM	306	Negative	0	mg / cm ^2	0.02
7/27/2021 10:13	DOOR FRAME	WOOD	D	INTACT	WHITE	3	LIVING ROOM	306	Negative	0	mg / cm ^2	0.02
7/27/2021 10:13	DOOR	WOOD	D	INTACT	WHITE	3	LIVING ROOM	306	Negative	0	mg / cm ^2	0.02
7/27/2021 10:13	HEATER	METAL	A	INTACT	WHITE	3	LIVING ROOM	306	Negative	0.01	mg / cm ^2	0.04
7/27/2021 10:14	WALL	DRYWALL	A	INTACT	WHITE	3	BEDROOM 1	306	Negative	0	mg / cm ^2	0.02
7/27/2021 10:14	WALL	DRYWALL	B	INTACT	WHITE	3	BEDROOM 1	306	Negative	0	mg / cm ^2	0.02
7/27/2021 10:15	WALL	DRYWALL	C	INTACT	WHITE	3	BEDROOM 1	306	Negative	0	mg / cm ^2	0.02
7/27/2021 10:15	WALL	DRYWALL	D	INTACT	WHITE	3	BEDROOM 1	306	Negative	0	mg / cm ^2	0.02
7/27/2021 10:15	CEILING	DRYWALL		INTACT	WHITE	3	BEDROOM 1	306	Negative	0	mg / cm ^2	0.02
7/27/2021 10:16	DOOR	WOOD	D	INTACT	WHITE	3	BEDROOM 1	306	Negative	0	mg / cm ^2	0.02
7/27/2021 10:16	DOOR FRAME	WOOD	D	INTACT	WHITE	3	BEDROOM 1	306	Negative	0	mg / cm ^2	0.02
7/27/2021 10:17	DOOR FRAME	WOOD	D	INTACT	WHITE	3	BATHROOM 1	306	Negative	0	mg / cm ^2	0.02
7/27/2021 10:17	DOOR FRAME	WOOD	A	INTACT	WHITE	3	BATHROOM 1	306	Negative	0	mg / cm ^2	0.02
7/27/2021 10:17	DOOR	WOOD	A	INTACT	WHITE	3	BATHROOM 1	306	Negative	0	mg / cm ^2	0.02
7/27/2021 10:18	CEILING	DRYWALL	A	INTACT	WHITE	3	BATHROOM 1	306	Negative	0	mg / cm ^2	0.02
7/27/2021 10:18	WINDOW	DRYWALL	A	INTACT	WHITE	3	BATHROOM 1	306	Negative	0	mg / cm ^2	0.02

XRF Readings
 Site: Bayshore Towers Apartments
 128 Perry Street
 Sandusky, OH 44870

Lead Risk Assessors:
 Charles Long / Joshua Fry

Time	Component	Substrate	Side	Condition	Color	Floor	Room	Apt. #	Results	PbC	Units	PbC Error
7/27/2021 10:18	WINDOW	DRYWALL	B	INTACT	WHITE	3	BATHROOM 1	306	Negative	0	mg / cm ^2	0.02
7/27/2021 10:19	WINDOW	DRYWALL	B	INTACT	WHITE	3	BATHROOM 1	306	Negative	0	mg / cm ^2	0.02
7/27/2021 10:19	WINDOW	DRYWALL	C	INTACT	WHITE	3	BATHROOM 1	306	Negative	0	mg / cm ^2	0.02
7/27/2021 10:19	WINDOW	DRYWALL	D	INTACT	WHITE	3	BATHROOM 1	306	Negative	0.01	mg / cm ^2	0.03
7/27/2021 10:21	WALL	DRYWALL	A	INTACT	WHITE	3	BEDROOM 2	306	Negative	0	mg / cm ^2	0.02
7/27/2021 10:21	WALL	DRYWALL	B	INTACT	WHITE	3	BEDROOM 2	306	Negative	0	mg / cm ^2	0.02
7/27/2021 10:21	WALL	DRYWALL	C	INTACT	WHITE	3	BEDROOM 2	306	Negative	0	mg / cm ^2	0.02
7/27/2021 10:22	WALL	DRYWALL	D	INTACT	WHITE	3	BEDROOM 2	306	Negative	0	mg / cm ^2	0.02
7/27/2021 10:22	DOOR	WOOD	C	INTACT	WHITE	3	BEDROOM 2	306	Negative	0	mg / cm ^2	0.02
7/27/2021 10:23	DOOR FRAME	WOOD	C	INTACT	WHITE	3	BEDROOM 2	306	Negative	0	mg / cm ^2	0.02
7/27/2021 10:23	CEILING	DRYWALL		INTACT	WHITE	3	BEDROOM 2	306	Negative	0	mg / cm ^2	0.02
7/27/2021 10:24	CEILING	DRYWALL		INTACT	WHITE	3	BEDROOM 2	306	Negative	0	mg / cm ^2	0.02
7/27/2021 10:25	CEILING	DRYWALL		INTACT	WHITE	3	BATHROOM 2	306	Negative	0	mg / cm ^2	0.02
7/27/2021 10:26	WALL	DRYWALL	A	INTACT	WHITE	3	BATHROOM 2	306	Negative	0	mg / cm ^2	0.02
7/27/2021 10:26	WALL	DRYWALL	B	INTACT	WHITE	3	BATHROOM 2	306	Negative	0	mg / cm ^2	0.02
7/27/2021 10:26	WALL	DRYWALL	C	INTACT	WHITE	3	BATHROOM 2	306	Null	0	mg / cm ^2	0.02
7/27/2021 10:26	WALL	DRYWALL	C	INTACT	WHITE	3	BATHROOM 2	306	Negative	0	mg / cm ^2	0.02
7/27/2021 10:27	WALL	DRYWALL	D	INTACT	WHITE	3	BATHROOM 2	306	Negative	0	mg / cm ^2	0.02
7/27/2021 10:27	DOOR	WOOD	D	INTACT	WHITE	3	BATHROOM 2	306	Negative	0	mg / cm ^2	0.02
7/27/2021 10:27	DOOR FRAME	WOOD	D	INTACT	WHITE	3	BATHROOM 2	306	Negative	0	mg / cm ^2	0.02
7/27/2021 10:31	WALL	DRYWALL	A	INTACT	WHITE	FIRST	ELEV HALL	COMMON	Negative	0	mg / cm ^2	0.02
7/27/2021 10:31	WALL	DRYWALL	B	INTACT	WHITE	FIRST	ELEV HALL	COMMON	Negative	0	mg / cm ^2	0.02
7/27/2021 10:31	WALL	DRYWALL	C	INTACT	WHITE	FIRST	ELEV HALL	COMMON	Negative	0	mg / cm ^2	0.02
7/27/2021 10:32	WALL	CONCRETE	C	INTACT	WHITE	FIRST	ELEV HALL	COMMON	Negative	0.08	mg / cm ^2	0.06
7/27/2021 10:32	WALL	CONCRETE	D	INTACT	WHITE	FIRST	ELEV HALL	COMMON	Negative	0	mg / cm ^2	0.02
7/27/2021 10:33	ELEV DOOR FRAME	METAL	C	INTACT	BROWN	FIRST	ELEV HALL	COMMON	Negative	0.04	mg / cm ^2	0.07
7/27/2021 10:33	ELEV DOOR	METAL	C	INTACT	BROWN	FIRST	ELEV HALL	COMMON	Negative	0.04	mg / cm ^2	0.06
7/27/2021 10:34	DOOR	METAL	A	INTACT	BROWN	FIRST	ELEV HALL	COMMON	Negative	0.02	mg / cm ^2	0.07
7/27/2021 10:36	HEATER	METAL	A	INTACT	WHITE	FIRST	WAITING ROOM	COMMON	Negative	0.01	mg / cm ^2	0.02
7/27/2021 10:36	WALL	DRYWALL	A	INTACT	WHITE	FIRST	WAITING ROOM	COMMON	Negative	0	mg / cm ^2	0.02
7/27/2021 10:37	WALL	DRYWALL	B	INTACT	WHITE	FIRST	WAITING ROOM	COMMON	Negative	0	mg / cm ^2	0.02
7/27/2021 10:37	WALL	DRYWALL	C	INTACT	WHITE	FIRST	WAITING ROOM	COMMON	Negative	0	mg / cm ^2	0.02
7/27/2021 10:37	WALL	DRYWALL	D	INTACT	WHITE	FIRST	WAITING ROOM	COMMON	Negative	0.4	mg / cm ^2	0.1
7/27/2021 10:38	WINDOW	METAL	D	INTACT	BROWN	FIRST	WAITING ROOM	COMMON	Negative	0	mg / cm ^2	0.02
7/27/2021 10:38	WALL	CONCRETE	D	INTACT	WHITE	FIRST	WAITING ROOM	COMMON	Negative	0	mg / cm ^2	0.02

XRF Readings
 Site: Bayshore Towers Apartments
 128 Perry Street
 Sandusky, OH 44870

Lead Risk Assessors:
 Charles Long / Joshua Fry

Time	Component	Substrate	Side	Condition	Color	Floor	Room	Apt. #	Results	PbC	Units	PbC Error
7/27/2021 10:39	DOOR	METAL	B	INTACT	BROWN	FIRST	WAITING ROOM	COMMON	Negative	0.01	mg / cm ^2	0.04
7/27/2021 10:39	DOORFRAME	METAL	B	INTACT	BROWN	FIRST	WAITING ROOM	COMMON	Negative	0	mg / cm ^2	0.02
7/27/2021 10:41	WALL	DRYWALL	A	INTACT	WHITE	FIRST	MENS RR	COMMON	Negative	0	mg / cm ^2	0.02
7/27/2021 10:41	WALL	DRYWALL	B	INTACT	WHITE	FIRST	MENS RR	COMMON	Negative	0	mg / cm ^2	0.02
7/27/2021 10:41	WALL	DRYWALL	C	INTACT	WHITE	FIRST	MENS RR	COMMON	Negative	0	mg / cm ^2	0.02
7/27/2021 10:42	WALL	DRYWALL	D	INTACT	WHITE	FIRST	MENS RR	COMMON	Negative	0	mg / cm ^2	0.02
7/27/2021 10:43	HEATER	METAL	C	INTACT	WHITE	FIRST	MENS RR	COMMON	Negative	0	mg / cm ^2	0.02
7/27/2021 10:43	DOOR	METAL	B	INTACT	BROWN	FIRST	MENS RR	COMMON	Negative	0	mg / cm ^2	0.02
7/27/2021 10:43	DOOR FRAME	METAL	B	INTACT	BROWN	FIRST	MENS RR	COMMON	Negative	0	mg / cm ^2	0.02
7/27/2021 10:47	DOOR FRAME	METAL	A	INTACT	BROWN	FIRST	ACTIVITY RM	COMMON	Negative	0	mg / cm ^2	0.02
7/27/2021 10:47	DOOR	METAL	A	INTACT	BROWN	FIRST	ACTIVITY RM	COMMON	Negative	0	mg / cm ^2	0.02
7/27/2021 10:48	WALL	DRYWALL	A	INTACT	WHITE	FIRST	ACTIVITY RM	COMMON	Negative	0	mg / cm ^2	0.02
7/27/2021 10:48	WALL	DRYWALL	B	INTACT	WHITE	FIRST	ACTIVITY RM	COMMON	Negative	0	mg / cm ^2	0.02
7/27/2021 10:48	WALL	DRYWALL	C	INTACT	WHITE	FIRST	ACTIVITY RM	COMMON	Negative	0	mg / cm ^2	0.02
7/27/2021 10:49	WALL	DRYWALL	D	INTACT	WHITE	FIRST	ACTIVITY RM	COMMON	Negative	0	mg / cm ^2	0.02
7/27/2021 10:50	HEATER	METAL	C	INTACT	WHITE	FIRST	ACTIVITY RM	COMMON	Negative	0	mg / cm ^2	0.02
7/27/2021 10:50	DOOR	WOOD	B	INTACT	WHITE	FIRST	ACTIVITY RM	COMMON	Negative	0	mg / cm ^2	0.02
7/27/2021 10:52	DOOR	METAL	D	INTACT	BROWN	FIRST	NORTH STAIR	COMMON	Negative	0.11	mg / cm ^2	0.09
7/27/2021 10:52	DOOR FRAME	METAL	D	INTACT	BROWN	FIRST	NORTH STAIR	COMMON	Negative	0.02	mg / cm ^2	0.04
7/27/2021 10:53	WALL	CONCRETE	A	INTACT	WHITE	FIRST	NORTH STAIR	COMMON	Negative	0	mg / cm ^2	0.02
7/27/2021 10:53	WALL	CONCRETE	B	INTACT	WHITE	FIRST	NORTH STAIR	COMMON	Negative	0	mg / cm ^2	0.02
7/27/2021 10:54	WALL	CONCRETE	C	INTACT	WHITE	FIRST	NORTH STAIR	COMMON	Negative	0	mg / cm ^2	0.02
7/27/2021 10:54	WALL	CONCRETE	D	INTACT	WHITE	FIRST	NORTH STAIR	COMMON	Null	0	mg / cm ^2	0.02
7/27/2021 10:54	WALL	CONCRETE	D	INTACT	WHITE	FIRST	NORTH STAIR	COMMON	Negative	0	mg / cm ^2	0.02
7/27/2021 10:54	HEATER	METAL	D	INTACT	BROWN	FIRST	NORTH STAIR	COMMON	Negative	0.17	mg / cm ^2	0.13
7/27/2021 10:56	HANDRAIL	METAL	A	INTACT	GRAY	FIRST	NORTH STAIR	COMMON	Negative	0.3	mg / cm ^2	0.14
7/27/2021 10:58	WALL	DRYWALL	A	INTACT	WHITE	FIRST	ENTRANCE A	COMMON	Negative	0	mg / cm ^2	0.02
7/27/2021 10:58	WALL	DRYWALL	B	INTACT	WHITE	FIRST	ENTRANCE A	COMMON	Negative	0	mg / cm ^2	0.02
7/27/2021 10:58	WALL	DRYWALL	C	INTACT	WHITE	FIRST	ENTRANCE A	COMMON	Negative	0	mg / cm ^2	0.02
7/27/2021 10:59	WALL	DRYWALL	D	INTACT	WHITE	FIRST	ENTRANCE A	COMMON	Negative	0	mg / cm ^2	0.02
7/27/2021 10:59	DOOR	METAL	A	INTACT	BROWN	FIRST	ENTRANCE A	COMMON	Negative	0	mg / cm ^2	0.02
7/27/2021 11:00	DOOR FRAME	METAL	A	INTACT	BROWN	FIRST	ENTRANCE A	COMMON	Negative	0	mg / cm ^2	0.02
7/27/2021 11:00	WINDOW	METAL	C	INTACT	BROWN	FIRST	ENTRANCE A	COMMON	Negative	0	mg / cm ^2	0.02
7/27/2021 11:01	WALL	CONCRETE	A	INTACT	WHITE	FIRST	ENTRANCE A	COMMON	Negative	0	mg / cm ^2	0.02
7/27/2021 11:07	CALCHECK								Positive	1	mg / cm ^2	0.1

XRF Readings
Site: Bayshore Towers Apartments
128 Perry Street
Sandusky, OH 44870

Lead Risk Assessors:
Charles Long / Joshua Fry

Time	Component	Substrate	Side	Condition	Color	Floor	Room	Apt. #	Results	PbC	Units	PbC Error
7/27/2021 11:07	CALCHECK								Positive	1.2	mg / cm ^2	0.1
7/27/2021 11:08	CALCHECK								Positive	1.1	mg / cm ^2	0.1

Appendix C

Site Maps

C

B

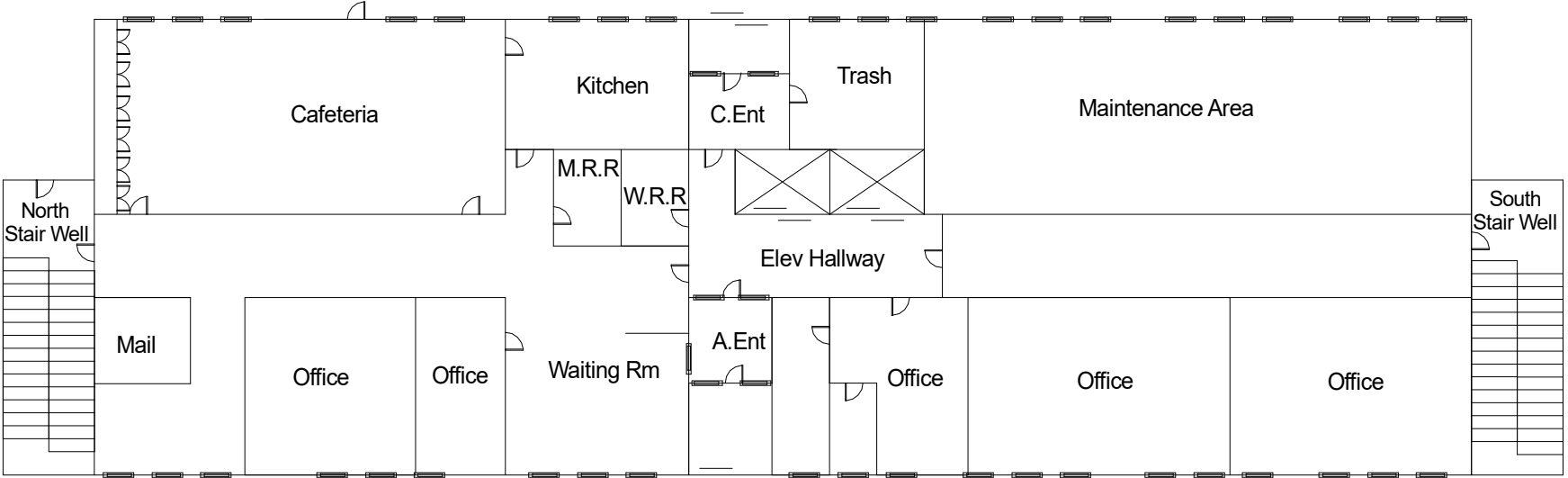

D

A

Figure 1	HazCorp Environmental Services, Inc.
	Drawn By: CDL
Site Map - 1st Floor Bayshore Towers 128 Perry St, Sandusky, OH 44870	

C

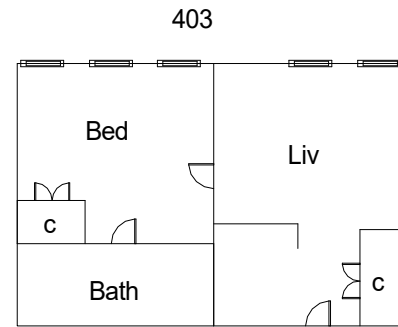
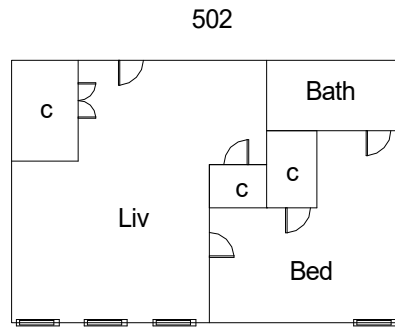
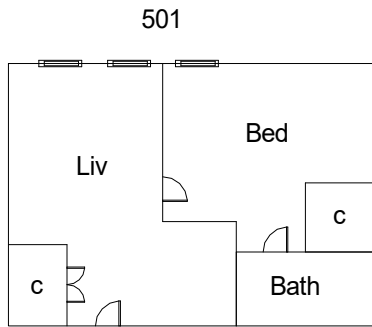

B

D

306

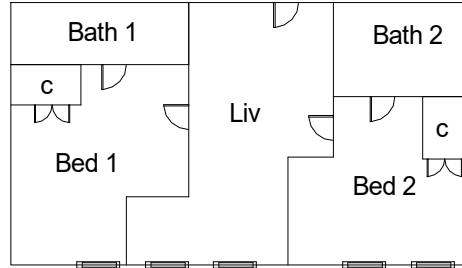

204

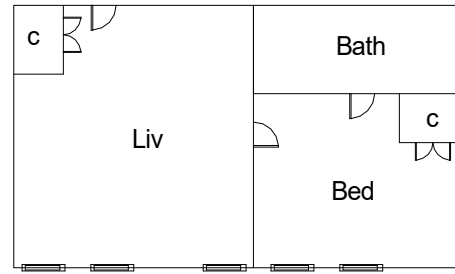

A

Figure 2	HazCorp Environmental Services, Inc.
	Drawn By: CDL
Site Map - Units 501,502,403,306,204 Bayshore Towers 128 Perry St, Sandusky, OH 44870	

C

709

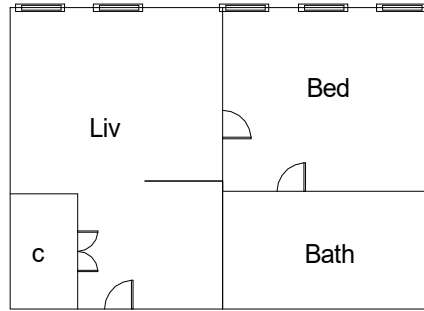

708

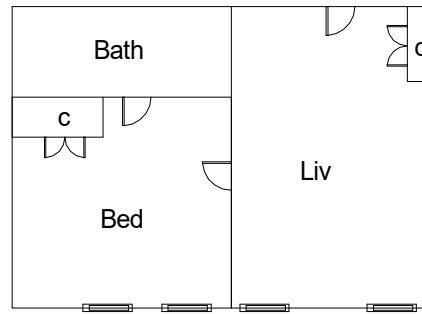

B

D

603

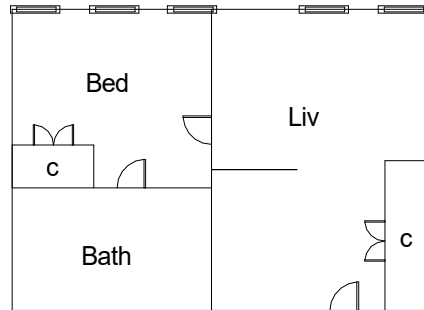

609

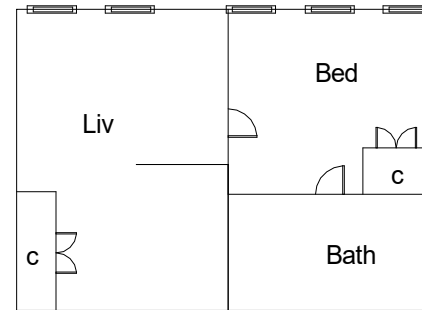

A

Figure 3

HazCorp Environmental Services, Inc.

Drawn By: CDL

Site Map - Units 603,609,709,708
Bayshore Towers
128 Perry St,
Sandusky, OH 44870

C

903

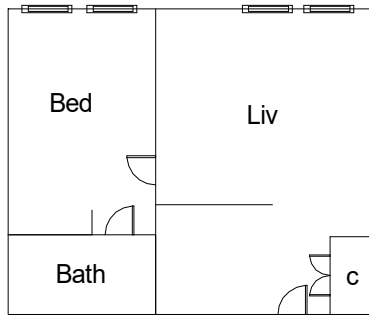

904

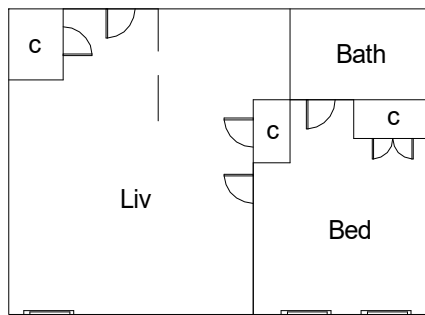

B

D

809

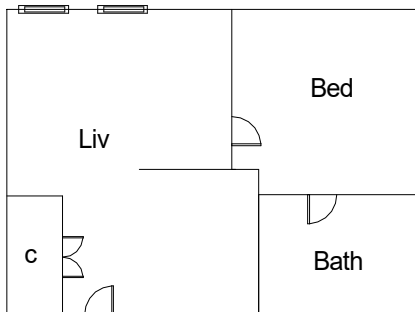

806

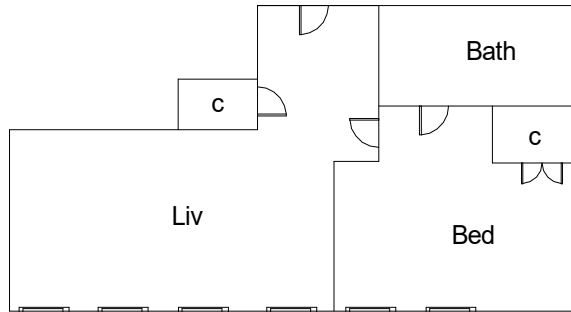

A

Figure 4

HazCorp Environmental Services, Inc.

Drawn By: CDL

Site Map - Units 806,809,903,904
Bayshore Towers
128 Perry St,
Sandusky, OH 44870

C

1204

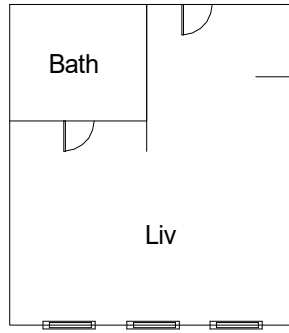

1203

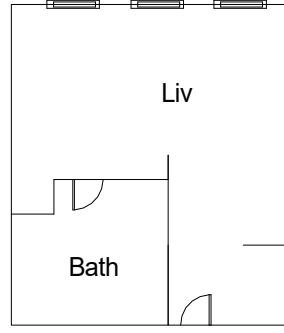

1113

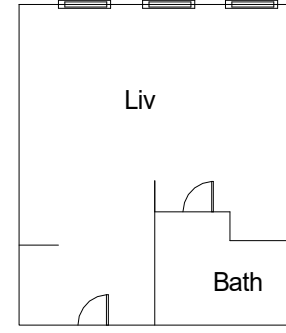

B

D

1112

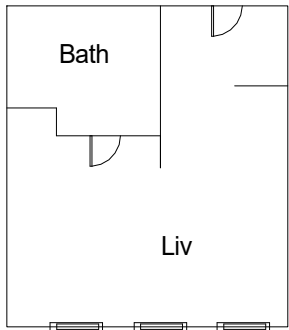

1011

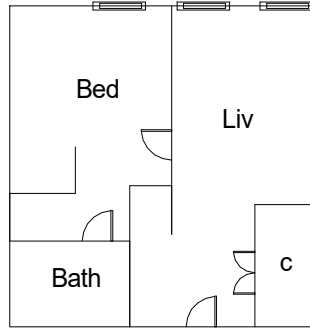

1006

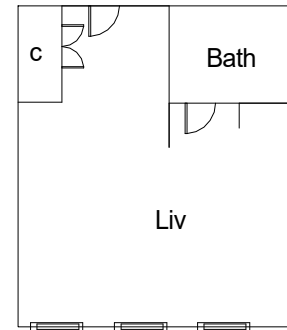

A

Figure 5

HazCorp Environmental Services, Inc.

Drawn By: CDL

Site Map - Units 1006,1011,1112,1113,1203,1204

Bayshore Towers

128 Perry St,

Sandusky, OH 44870

Appendix D

Certifications and Licenses



Department
of Health

Mike DeWine, Governor
Jon Husted, Lt. Governor

Amy Acton, MD, MPH, Director

March 13, 2020

Charles D Long
2523 Revilla Dr
Northwood OH 43619

RE: Lead Risk Assessor
License Number: LA007439
Expiration Date: 03/31/2022

Dear Charles D Long:

This letter and enclosed license approves your request to be licensed as a Lead Risk Assessor. You must present your license upon request at any project site while performing duties. A copy of your license is not acceptable as proof of licensure.

Please be aware of the rules and regulations governing your discipline for Ohio. If you choose to renew this license, you must take an Ohio approved refresher course appropriate for the discipline within 2 years of your previous training course. Please visit our website at www.odh.ohio.gov for information.

This license may be revoked by the Director of Health for violation of any of the requirements of 3701-32 of the Ohio Administrative Code.

If you have any questions, please call the Ohio Department of Health, Lead Poisoning Prevention Program at (614) 466-1450.

Sincerely,

Shamus Estep, R.S.
Program Administrator
Bureau of Environmental Health and Radiation Protection

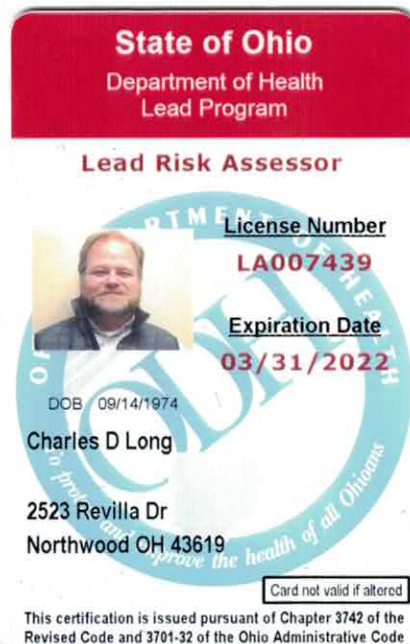



Department
of Health

Mike DeWine, Governor
Jon Husted, Lt. Governor

Stephanie McCloud, Director

January 27, 2021

Joshuah Fry
HazCorp Environmental Services
805 Capital Commons Drive
Toledo OH 43615

RE: Lead Risk Assessor
License Number: LA9573
Expiration Date: 01/20/2023

Dear Joshuah Fry:

This letter and enclosed license approves your request to be licensed as a Lead Risk Assessor. You must present your license upon request at any project site while performing duties. A copy of your license is not acceptable as proof of licensure.

Please be aware of the rules and regulations governing your discipline for Ohio. If you choose to renew this license, you must take an Ohio approved refresher course appropriate for the discipline within 2 years of your previous training course. Please visit our website at www.odh.ohio.gov for information.

This license may be revoked by the Director of Health for violation of any of the requirements of 3701-32 of the Ohio Administrative Code.

If you have any questions, please call the Ohio Department of Health, Lead Poisoning Prevention Program at (614) 466-1450.

Sincerely,

Shamus Estep, R.S.
Program Administrator
Bureau of Environmental Health and Radiation Protection





National Institute of Standards & Technology

Certificate of Analysis

Standard Reference Material[®] 2573

Lead Paint Film

For Portable X-Ray Fluorescence Analyzers – Nominal 1.0 mg/cm²
(Color Code: Red)

This Standard Reference Material (SRM) is intended for checking the calibration of portable, hand-held, x-ray fluorescence analyzers when testing for lead in paint coatings on interior and exterior building surfaces. A unit of SRM 2573 consists of a white polyester sheet, approximately 7.6 cm wide, 10.2 cm long, and 0.2 mm thick, coated with a single, red-colored paint layer, approximately 0.04 mm thick. A blank, SRM 2570, is also provided. The blank is coated with a lead-free, lacquer layer on a white polyester sheet of the same thickness as the lead paint samples. All sheets are over-coated with a clear, thin, plastic laminate to protect the surface from abrasion. SRM 2573 and SRM 2570 are two of a set of six paint films (SRM 2570 to SRM 2575) available as SRM 2579a.

The certified values for lead for this SRM and the blank, SRM 2570, are reported in Table 1 in units of mg/cm². These values are based on measurements by isotope dilution inductively-coupled plasma mass spectrometry.

Table 1. Certified Lead Values

Level	Color Code	Lead Concentration, in mg/cm ²
SRM 2570	White (Blank)	<0.001
SRM 2573	Red	1.040 ± 0.064

The uncertainty of each certified value is expressed as an expanded uncertainty, U , at the 95 % level of confidence and is calculated according to the method described in the ISO Guide [1,2]. Because of variability in the paint film between different sheets of each SRM, the uncertainties are 95 % prediction intervals. The expanded uncertainty is calculated as $U = ku_c$, where u_c is intended to represent, at the level of one standard deviation, the combined uncertainty due to material variability and measurement uncertainty. The coverage factor, k , is determined from the Student's t -distribution corresponding to the calculated effective degrees of freedom and 95 % level of confidence.

Expiration of Certification: The certification of SRM 2573 is valid, within the measurement uncertainties specified, until **01 July 2020**, provided the SRM is handled and stored in accordance with the instructions given in this certificate (see "Instructions for Use"). The certification is nullified if the SRM is damaged, contaminated, or otherwise modified.

Maintenance of SRM Certification: NIST will monitor this SRM over the period of its certification. If substantive technical changes occur that affect the certification before the expiration of this certificate, NIST will notify the purchaser. Registration (see attached sheet) will facilitate notification.

The overall direction and coordination of the analytical measurements leading to certification were performed by G.C. Turk and J.D. Fassett of the NIST Analytical Chemistry Division. Analytical measurements were performed by K.E. Murphy, J.R. Sieber, A.F. Marlow, L.J. Wood, P.R. Seo, and M. Lankosz of the NIST Analytical Chemistry Division. The SRM was fabricated under the direction of J.R. Sieber of the NIST Analytical Chemistry Division.

Stephen A. Wise, Chief
Analytical Chemistry Division

Robert L. Watters, Jr., Chief
Measurement Services Division

Gaithersburg, MD 20899
Certificate Issue Date: 24 March 2009
See Certificate Revision History on Last Page

Statistical consultation for this SRM was provided by E.S. Lagergren and N.F. Zhang of the NIST Statistical Engineering Division.

Support aspects involved in the issuance of this SRM were coordinated through the NIST Measurement Services Division.

NOTICE AND WARNING TO USERS

NOTE: This SRM contains lead, as a lead chromate pigment, which is toxic and a suspected carcinogen to the lung and kidney. The SRM must be handled with care and disposed of according to the U.S. Environmental Protection Agency (EPA) practices and procedures.

INSTRUCTIONS FOR USE

The SRM sheet must first be removed from the plastic sleeve in which it is stored and then positioned so that the side labeled with the NIST logo and SRM number faces the x-ray source. For best results, the size of the x-ray beam from the field unit should irradiate an area of the SRM that is at least 2.5 cm in diameter and is centered on the sheet. Care must be exercised not to compromise the protective plastic laminate which prevents scratching or chipping of the painted surface and the potential release of dust containing lead. Upon completion of the measurement, the SRM must be re-stored in the plastic sleeve provided. It is also recommended that this SRM be stored indoors at ambient room temperature and away from direct sunlight when not in use.

Stability: This SRM is considered to be stable during the period of certification. NIST will monitor the SRM and will report any significant changes in certification to the purchaser. Return of the attached registration card will facilitate notification.

PREPARATION

SRM Preparation: The paint-coated, polyester sheets were prepared by an automated coating process at a commercial facility under contract to NIST. Known concentrations of a lead chromate pigment were dispersed in a commercial paint vehicle to prepare the lead paints. A lead-free, organic tint was added to each paint mixture to give the desired color. A thin, protective overlay of plastic laminate was applied to each paint film. The attenuation of lead $L_{3-}M_{4,5}$ ($L\alpha_{1,2}$) X-rays due to the protective overlay does not exceed 2 % relative, while that of $K-L_{2,3}$ ($K\alpha_{1,2}$) x-rays commonly used for field measurement is negligible.

REFERENCES

- [1] ISO; *Guide to the Expression of Uncertainty in Measurement*; ISBN 92-67-10188-9, 1st ed., International Organization for Standardization: Geneva, Switzerland (1993); see also Taylor, B.N.; Kuyatt, C.E.; *Guidelines for Evaluating and Expressing the Uncertainty of NIST Measurement Results*; NIST Technical Note 1297, U.S. Government Printing Office: Washington, DC (1994); available at <http://physics.nist.gov/Pubs/>.
- [2] Hahn, G.J.; Meeker, W.Q.; *Statistical Intervals: A Guide for Practitioners*; John Wiley & Sons, Inc., New York, NY (1991).

Certificate Revision History: 24 March 2009 (Extension of certification period); 29 November 1999 (Original certificate date).
--

Users of this SRM should ensure that the certificate in their possession is current. This can be accomplished by contacting the SRM Program at: telephone (301) 975-2200; fax (301) 926-4751; e-mail srminfo@nist.gov; or via the Internet at <http://www.nist.gov/srm>.